

TELEVISION ENGINEERING

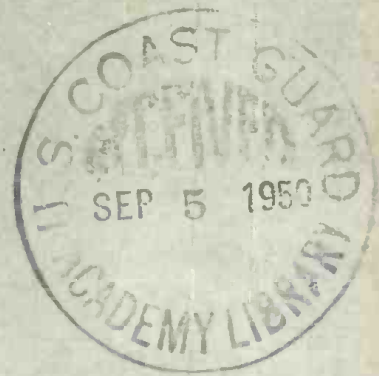

AUGUST, 1950

ENGINEERING

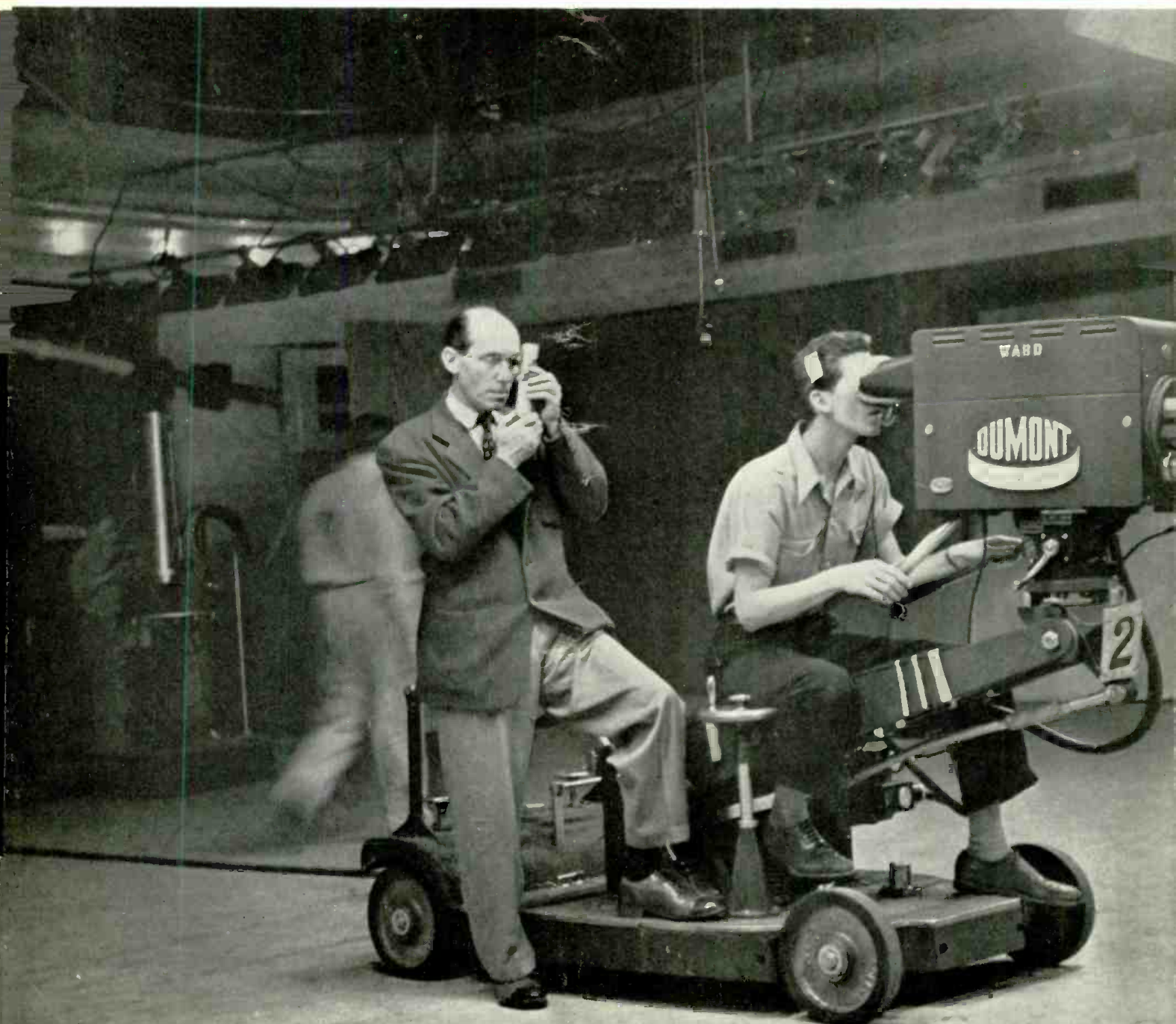

Predetermining studio lighting with an exposure photometer.

Controlling the Nation's **TV AND RADIO!**

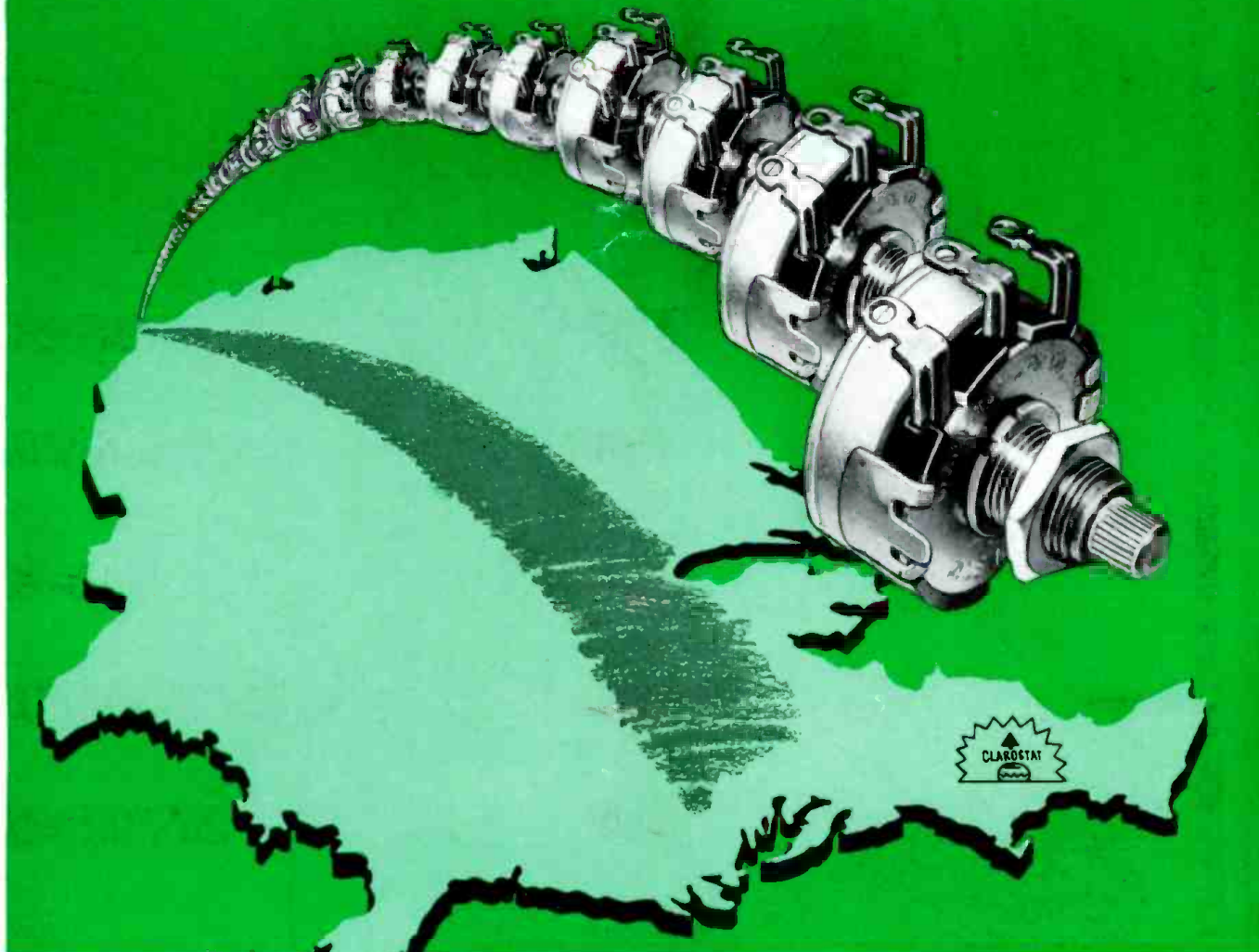

Clarostat supplies more controls for TV than any other manufacturer. Three decades of pioneering and specialization are duly recognized. And Clarostat's new plant with unexcelled mechanization and smoothest production flow, turns out over 50,000 controls a day, not to mention resistors of many different types, in meeting the major portion of today's TV and radio requirements. Obviously, for quality, uniformity, dependability, economy, it's CLAROSTAT.

Write for Engineering Bulletins on resistors, controls and resistance devices. Let us collaborate on your control and resistance problems and needs.

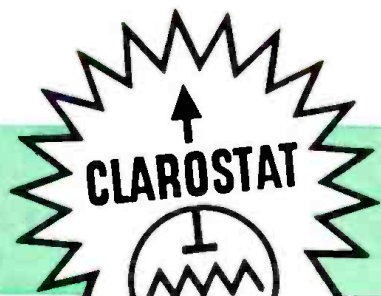

Controls and Resistors

CLAROSTAT MFG. CO., INC. • DOVER, NEW HAMPSHIRE
IN CANADA: CANADIAN MARCONI CO. LTD., MONTREAL, P. Q., AND BRANCHES

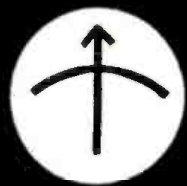

MEASUREMENTS CORPORATION

Laboratory Standards

QUALITY ELECTRONIC
MEASURING INSTRUMENTS
FOR ACCURATE, DEPENDABLE SERVICE

NEW!

CRYSTAL
CALIBRATOR
Model 111

250 Kc. to 1000 Mc.



U. H. F. OSCILLATOR
Model 112
300 Mc. to 1000 Mc.



STANDARD SIGNAL GENERATOR
Model 82
20 Cycles to 50 Mc.

MEGACYCLE
METER
Model 59

2.2 Mc. to 400 Mc.



STANDARD SIGNAL GENERATORS

MODEL	FREQUENCY RANGE	OUTPUT RANGE	MODULATION
65-B	75 Kc.-30 Mc.	0.1 microvolt to 2.2 volts	AM. 0 to 100% 400 cycles or 1000 cycles External mod., 50-10,000 cycles
78	15-25 Mc.; 195-225 Mc. 15-25 Mc.; 90-125 Mc. other ranges on order	1 to 100,000 microvolts	AM. 8200-400 cycles 625-400 cycles Fixed at approximately 30%
78-FM	86 Mc.-108 Mc.	1 to 100,000 microvolts	Deviation 0-300 kc, 2 ranges FM. 400-8200 cycles External modulation to 15 Kc.
80	2 Mc.-400 Mc.	0.1 to 100,000 microvolts	AM. 0 to 30% 400 cycles or 1000 cycles External mod., 50-10,000 cycles.
82	20 cycles to 200 Kc. 80 Kc. to 50 Mc.	0-50 volts 0.1 microvolt to 1 volt	Continuously variable 0-50% from 20 cycles to 20 Kc.
84	300 Mc.-1000 Mc.	0.1 to 100,000 microvolts	AM. 0 to 30%, 400, 1000, or 2500 cycles. Internal pulse modulator. External mod., 50-30,000 cycles.
90	20 Mc.-250 Mc.	0.3 microvolt to 0.1 volt	Continuously variable, 0 to 100% Sinusoidal modulation 30 cycles. 5 Mc. Composite TV modulation.

U. H. F. OSCILLATOR

MODEL	FREQUENCY RANGE	OUTPUT RANGE	OUTPUT IMPEDANCE
112	300 Mc. - 1000 Mc.	Maximum varies between 0.3 volt and 2 volts. Adjustable over 40 db range	50 ohms

PULSE GENERATOR

MODEL	FREQUENCY RANGE	PULSE WIDTH	OUTPUT
79-B	60 to 100,000 cycles	Continuously variable from 0.5 to 40 microseconds	Approximately 150 volts positive with respect to ground. "Sync Output" 75 volts positive with respect to ground.

SQUARE WAVE GENERATOR

MODEL	FREQUENCY RANGE	WAVE SHAPE	OUTPUT
71	Continuously variable 6 to 100,000 cycles	Rise time less than 0.2 microseconds with negligible overshoot	Step attenuator: 75, 50, 25, 15, 10, 5 peak volts fixed and 0 to 2.5 volts continuously variable.

U.H.F. RADIO NOISE and FIELD STRENGTH METER

MODEL	FREQUENCY RANGE	INPUT VOLTAGE RANGE
58	15 Mc. to 150 Mc.	1 to 100,000 microvolts in antenna. 1 to 100 microvolts on semi-logarithmic output meter, balanced resistance attenuator with ratios of 10, 100 and 1000 ahead of all tubes.

VACUUM TUBE VOLTMETERS

MODEL	VOLTAGE RANGE	FREQUENCY RANGE	INPUT IMPEDANCE
62	0-1, 0-3, 0-30 and 0-100 volts AC or DC	30 cycles to over 150 Mc.	Approximately 7 mmfd.
62-U.H.F.	0-1, 0-3, 0-30 and 0-100 volts AC or DC	100 Kc. to 500 Mc.	Approximately 2 mmfd.
67	.0005 to 300 volts peak-to-peak	5 to 100,000 sine-wave cycles per second	1 megohm shunted by 30 mmfd.

MEGACYCLE METER

MODEL	FREQUENCY RANGE	FREQUENCY ACCURACY	MODULATION
59	2.2 Mc. - 400 Mc.	Within $\pm 2\%$	CW or 120 cycles fixed at approximately 30%. Provision for external modulation

CRYSTAL CALIBRATOR

MODEL	FREQUENCY RANGE	FREQUENCY ACCURACY	HARMONIC RANGE
111	250 Kc. - 1000 Mc.	0.001%	.25 Mc. Oscillator: .25-450 Mc. 1 Mc. Oscillator: 1-600 Mc. 10 Mc. Oscillator: 10-1000 Mc.

BRIDGES

MODEL	INDUCTANCE (L)	CAPACITANCE (C)	AC RESISTANCE (R)
102	0.5 microhenry to 110 henries	1 mmf. to 110 mfd. Power factor 0-30%	1 ohm to 11 megohms

MEASUREMENTS CORPORATION • BOONTON, N. J.

TELEVISION ENGINEERING

Including Radio Engineering, Communications and Broadcast Engineering. Registered U. S. Patent Office.

Research . . . Design . . . Production . . . Instrumentation . . . Operation

VOLUME I

AUGUST, 1950

NUMBER 8

Predetermining TV Studio Lighting.....	Frank G. Back	6
<i>Application of Video Analyzer and Exposure Photometer of Extinction Type Found to Serve as Gauge to Proper Mood Lighting Within Pickup to Capabilities of Image Orthicon Camera.</i>		
Versatile Phase-Shift Control for Studio Sync Generator.....	C. J. Auditore	8
<i>System. Using a Selsyn Unit. Permits Rapid Adjustment of Vertical Sync Phase.</i>		
Vibration Fatigue Testing of TV Antennas.....	Ken Lippert	11
<i>Mechanical Test Procedures Adopted to Disclose Vital Physical-Design Information.</i>		
The Streamlining of TV Chassis.....	Wyn Martin	12
<i>New Chassis Design Trends Which Feature Consolidation of Separate Parts Into Pre-Wired Assemblies Arranged in Functional Order.</i>		
Tube Production Line Techniques.....		14
<i>Pictorial Review of Tube Manufacturing Facilities at Sylvania and RCA Plants.</i>		
Coverage of Standard Frequency Station WWVH.....	E. L. Hall	16
<i>Report of Observations of 400-Watt Experimental Transmitter Operating on 5, 10 and 15 Mc.</i>		
The Hazeltine Color Tests.....	P. B. Lewis	22
<i>Highlights of Systems Study, Which Revealed That Dot-Sequential Method Offers Best Solution Possibilities. With New Constant-Luminance Sampling Technique Providing Significant Reception Advantages.</i>		
R C Tuning Network Bandspreading and Scale Equalization	C. F. Van L. Weiland	28
<i>Part III . . . Systems Evolved to Provide Partial Equalization and Completely Equalized Bandspreading.</i>		

MONTHLY FEATURES

Viewpoints	Lewis Winner	5
TV Tube Developments.....		14
Production Aids		19
TV Parts and Accessories.....		20
Instrument News		21
Personals		25
Industry Literature		25
Veteran Wireless Operators' Association News.....		27
Briefly Speaking		32
Advertising Index		32

Cover Illustration

Application of exposure photometer to pre-determine studio lighting: See page 6, this issue, for detailed report on equipment and procedures used in this new technique.

Editor: LEWIS WINNER



Published monthly by Bryan Davis Publishing Co., Inc., 52 Vanderbilt Avenue, New York 17, N. Y. Telephone: MURRAY HILL 4-0170.



Bryan S. Davis, President. Paul S. Weil, Vice-Pres.-Gen. Mgr. Lewis Winner, Editorial Director. F. Walen, Secretary. A. Goebel, Circulation Manager.

Mid-West Representative: Stuart J. Osten, 333 N. Michigan Ave., Chicago 1, Illinois. Telephone: Dearborn 2-3507
 Eastern Representative: J. I. Brookman, 52 Vanderbilt Avenue, New York 17, N. Y.
 East-Central Representative: James C. Munn, 2253 Delaware Drive, Cleveland 6, Ohio. Telephone: ERieviev 1-1726.
 Pacific Coast Representative: Brand & Brand, 1052 West 8th Street, Los Angeles 14, Cal. Telephone: Michigan 1732.
 Suite 1204, Russ Building, San Francisco 4, Cal. Telephone: SUtter 1-2251.

Reentered as second-class matter February 7, 1950 at the Post Office at New York, N. Y., under the act of March 3, 1879. Subscription Price: \$3.00 per year in the United States of America and Canada; 50c per copy. \$4.00 per year in foreign countries; 60c per copy.

The Aro Book Depot: Wellington, New Zealand. McGill's Agency: Melbourne, Australia.

TELEVISION ENGINEERING is indexed in the Engineering Index.
 Entire Contents Copyright 1950, Bryan Davis Publishing Co., Inc.

**These famous names in
the sky...have a famous
friend in SYLVANIA**

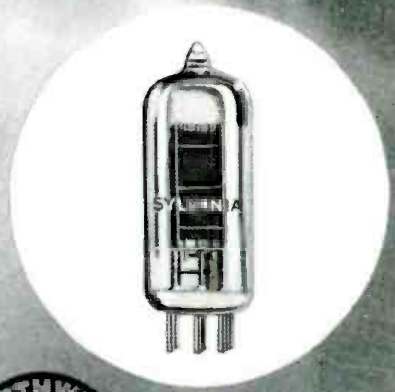

Wherever these famous airliners fly, a trusted group of friendly guides goes with them, in the form of Sylvania Radio Tubes.

For, the dependability, long life, and splendid performance of Sylvania Tubes have won them top preference with radio and electronics engineers throughout this country, as well as abroad.

Sylvania's ruggedized tubes are typical examples of the alert engineering which is responsible for the

increasing demand for all Sylvania quality products.

What is your problem?

Let Sylvania radio research and advanced engineering work for you. If you have problems—as widely varied as the designing of more compact sets, and the overcoming of shock and vibration—put them up to Sylvania. Address your letters to Radio Tube Division, Dept. R-2608, Emporium, Pa.

SYLVANIA  ELECTRIC

RADIO TUBES; TELEVISION PICTURE TUBES; ELECTRONIC PRODUCTS; ELECTRONIC TEST EQUIPMENT; FLUORESCENT LAMPS; FIXTURES; SIGN TUBING; WIRING DEVICES; LIGHT BULBS; PHOTOLAMPS; TELEVISION SETS

Field Tested Antenna Installation Information



Over 35,000 words of vital data . . . With over 130 photos and drawings . . . Detailed illustration and subject index for rapid reference.

∨∨ "The best book on the market at this time dealing with the problem of television antennas and antenna installation . . . If more Service Men would read this book, it would help them considerably in making better installations and providing better television reception for their customers."—*M. J. Shapp, President, Jerrold Electronics Corp.*

∨∨ "Will recommend it to all the Service Men and technical people I meet."—*Charles Cahn, Field Service Engineer, Bendix Radio.*

∨∨ "Well organized and illustrated, very complete and up-to-date, carefully detailed. It will definitely improve the ability of the man who studies it and therefore is mighty useful to a firm like ours."—*Hamilton Hoop, President, United States Television Mfg. Corp.*

∨∨ "Will certainly fill a long-felt need for some practical information . . . sincerest congratulations."—*George P. Adair, Former Chief Engineer, FCC, and now Consultant in Washington, D. C.*

∨∨ "A thorough-going compendium of the installing art . . . Going to recommend it highly to our Service Control Department and our service organizations."—*Ernest A. Marx, General Manager, Television Receiver Sales Div., Allen B. DuMont Laboratories, Inc.*

∨∨ "Informative and extremely well written."—*R. Morris Pierce, President and General Manager, WDOI.*

∨∨ "Most complete analysis of the antenna installation problem I have seen as yet."—*A. T. Alexander, Service Manager, Motorola, Inc.*

∨∨ "First really good publication I have found on the subject."—*E. K. Jett, Former FCC Commissioner and now Vice-President, WMAR.*

∨∨ "I have just finished looking through your book . . . and find it very interesting and informative."—*A. James Ebel, Director of Engineering, Peoria Broadcasting Co.*

∨∨ "The Radio-Television Division of the Massachusetts Trades Shops Schools has just decided to incorporate the book within its curriculum . . . The book will be issued to all future television starting classes at the school."—*Donald M. Barse, Purchasing Agent, Massachusetts Trades Shops School, Boston.*

TV-FM Antenna Installation

by IRA KAMEN

TV Antenna Consultant

and LEWIS WINNER

Editorial Director,

Bryan Davis Pub. Co., Inc.;

Editor, SERVICE and TELEVISION ENGINEERING

The *only practical book* on the key link to TV and FM reception . . . based entirely on actual, roof-top experiences in the most active TV and FM areas in the country.

The *first book* in which you'll find complete design and installation information on every type of TV and FM receiving antenna and accessory.

10 Fact-Packed Chapters on . . .

Installation Tools	Fringe Reception
Antenna Installation Procedures	Master Antenna Systems
Securing 12-Channel Coverage	FM Antennas
HF Antenna Installations	Installation Business Practices
TV Interference	Tricks of the Trade

At your Jobber or Order
Direct . . . \$2.00 Postpaid

BRYAN DAVIS PUBLISHING CO., INC., Book Dept.
52 Vanderbilt Avenue, New York 17, N. Y.

Send me a copy of TV . . . FM Antenna Installation, postpaid, for which I am enclosing \$2.00.

(Please print)

NAME

ADDRESS

CITY AND STATE.....

TELEVISION ENGINEERING

LEWIS WINNER, Editor

August, 1950

The Condon Report

COLOR TV, with its three systems, the merits of which have been bitterly disputed by many and excitingly applauded by others, during a 270-day battle of words and tests in and about Washington, recently received an independent appraisal by an official advisory committee, an appraisal which was quickly adopted as a key guide in the planning of a pattern for the new art.

Cited as a report on *the present status of color television*, the study prepared by a group of four under the guidance of the director of the National Bureau of Standards, Edward U. Condon, provides for the first time a lucid impartial evaluation of what the field, dot, and line methods have to offer now, and their possible potentialities.

Declaring that the three systems are mutually exclusive and one, and only one, must be chosen prior to the inauguration of a public service, the report also discloses that each of the systems does have plus and minus features which must be considered. In the CTI approach, for instance, we are told that it is possible to achieve a resolution and a large-area flicker performance equivalent to the black and white system, but there is a deficiency in the apparent vertical resolution and small-area flicker performance. The system is also described as being subject to registration difficulties and not able to employ the 6-mc channel width effectively, since neither the dot-interlaces nor the mixed-highs principles are employed. Reviewing the flicker brightness relationship of the system, the report declares that the small-area flicker effects are accentuated by the fact that each line is scanned in any one primary color only ten times per second, and moreover two lines of the same color in any one field are separated by two other lines in different colors, plus three blank spaces. These two effects together cause an apparent motion of the lines upward or downward in the picture, known as line crawls. Therefore, says the report, in common with all flicker effects, line crawl becomes more pronounced if the image becomes brighter.

Analyzing the characteristics of the CBS field-sequential method, the report states that the interlaced version of the system has substantially poorer resolution than the black and white system, and the dot-interlaced version has slightly poorer resolution than the monochrome method. The report goes on to state that the large-area flicker-brightness performance of the CBS system is inferior to that of the black and white, which means that a CBS color image cannot be as bright, by a factor of five to ten times, as the black and white image, for equal freedom from flicker. In the opinion of these experts, however, the color fidelity of this system is superior to that of the other systems, due to the maintenance of better color balance

and more accurate registration, both of which are implicit in the use of but one scanned surface in the camera and one in the receiver.

Summarizing the properties of the RCA dot-sequential method, the committee notes that the RCA color image has an overall resolution approximately equal to that of the black and white system, the finest details being depicted in shades of gray, while the larger details are rendered in color. The large-area flicker-brightness and continuity performance of the system was also found to be equal to that of the black and white method, while the small-area performance was cited as being somewhat inferior, due to the fact that the color picture rate is fifteen per second or half of the corresponding rate in the monochrome setup.

In a probe of the eventual possibilities of each system, the committee found that the CBS system has progressed furthest toward full realization of its potentialities, but its flicker-brightness performance is not capable of substantial improvement and it is not likely that the system will improve in its channel utilization. The commentary on the CTI system disclosed that while the method is less fully developed, it has a somewhat greater possibility of further improvement, particularly with respect to the correction of faulty registration and small-area color distortions. However, it was pointed out that this system cannot reasonably be expected to overcome certain inherent limitations, imposed by the choice of the scanning method, which include the difficulty of avoiding interlining flicker and the impracticability of using dot-interlace, at a color picture rate of five per second which is too low for the satisfactory rendition of small areas and sharp edges. The RCA system, in the opinion of the committee members, also has considerable opportunity for improvement, and registration of the color images, as well as the balance of the color values in both large and small areas can be expected to improve substantially with advances in camera design.

The report also referred to the recently demonstrated Hazeltine constant-luminance sampling technique¹ which considerably reduces the visible effect of noise and interference in a dot-sequential color image. This test, the report states, offers conclusive proof of the value of the mixed-highs approach.

In a generalized review of the future of color TV, the committee members declared that once the decision is reached among the systems, it may be found that the real limit to future progress is that imposed by the nature of the scanning standards, not by the present equipment limitations or present relative costs.

Everyone we are certain, is genuinely grateful to this committee for this comprehensive, frank review on color TV . . . today and tomorrow.—L.W.

¹See page 22, this issue, for a report on this system.



Scene simulating bright sunlight illumination, subject being lighted so as to place one side in a bright light, and other in shadow.



A dull-day illumination setup, with values of shaded areas as well as of highlights decreased and illumination diminished.

Predetermining

IN TV LIGHTING, two basic requirements must be fulfilled. The lighting must create the mood called for by the script and it must be acceptable to the pickup tubes being used in the cameras.

It has been found that through an intelligent blending and distribution of floodlights and spotlights, it is not difficult to obtain a desired lighting mood, which normally involves bright sunlight, a dull overcast day, and a night scene. To simulate bright sunlight, the subject must be lighted so as to place one side in bright light, the other in shadow. Since the subject must cast a shadow, the illumination must be directional. Finally, the background must be well lighted. Similarly, to produce

the effect of a dull day, the values of the shaded areas, as well as of the highlights, must be decreased and the illumination of the background must be lessened. The subject should cast no deep shadow. Finally, to create a night effect, we must have a dark background while the subject must be highlighted on one side and be in deep shadow on the other. Some backlighting should be used if possible.

In television, however, the most dramatic and artistic lighting can fail if the camera pickup tube is unable to translate that lighting into a faithful image. If the light range in a scene exceeds the capabilities of the camera tube, if the highlights are too bright

and the shadows are too dark, the image quality suffers. Unfortunately, the human eye is a poor judge of light and dark values.

Even the conventional type of exposure or light meter has not been found satisfactory for the judgment of TV illumination. By design, these devices measure only the overall value of the reflected light and do not reveal the brightness of the light reflected from individual subjects or the parts of individual subjects. Thus, it is impossible to gauge the brightness range; the difference in value between the brightest highlight and the deepest shadow. In addition, these devices provide no adequate means for arranging studio



Left:
A scene in which night effect illumination has been simulated. Here the subject has been highlighted on one side and placed in deep shadows on the other.

Below:
The video analyzer used in predetermining of lighting.



Use of Video Analyzer and Exposure Photometer of the Extinction Type Permits Control of Desired Lighting Mood Within Pickup Capabilities of Image Orthicon Camera.



Right:
Recently developed exposure photometer.

TV Studio Lighting

by FRANK G. BACK, President, Zoomar Corporation

illumination to meet the requirements of the camera tubes being used.

By combining the capabilities of a *video analyzer*¹ and an *exposure photometer*,² it has been found possible to not only adjust the studio lighting for mood, but match the lighting accurately to the characteristics of the image orthicons in the cameras.

The *video analyzer* permits measurement of a tube's sensitivity and saturation point in terms of *f-stop* openings. Using these data, it is possible to obtain the tube's contrast number (saturation number sensitivity number equals contrast number). Since we know, for instance, that the No. 6 wedge on the analyzer's gray scale, used to determine saturation point, transmits 20 footlamberts of light, and that the No. 1 wedge, used to determine a tube's sensitivity, transmits 2/3 footlambert, it will be found that the ratio of minimum light level to maximum light level for a tube having a contrast number of 1 will be 30 (20 divided by 2/3). This means that when using an image orthicon, whose saturation and sensitivity numbers are the same, the brightest bright

in an illuminated scene being televised should be no more than thirty times brighter than the darkest dark in terms of reflected light. This is the brightness range, which for any tube is equal to 30 divided by the square of the tube's contrast number; $B R = 30 C^2$.

As an example, let us suppose that we have an image orthicon with a saturation, *f*, number of 16, and a sensitivity, *f*, number of 8. Its contrast number will then be 2 (16/8), while its brightness range will be approximately 3 (30/2²). This means that, for that par-

ticular camera tube, the brightest bright in an illuminated scene must never be more than eight times as bright as the darkest dark, in terms of reflected light. The reflected illumination always must be kept well within a tube's brightness range.

How do we check the reflected light? Unlike the conventional type of light meter, the *photometer*,² which is of the extinction type, permits the measurement, in footlamberts, of the light reflected from the smallest areas. It has

(Continued on page 24)

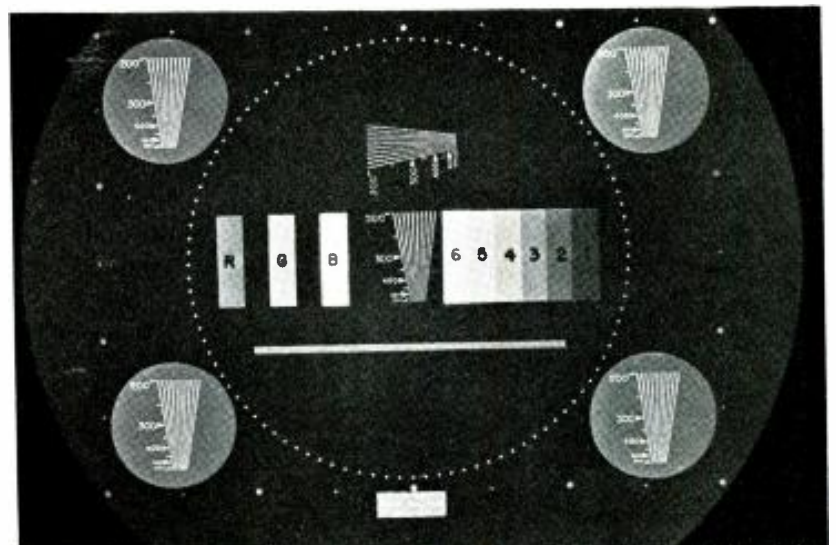

Right:
Video analyzer target.

Versatile Phase-Shift Control for TV Studio Sync Generator

Device, Employing Selsyn System, Affords Rapid Adjustment of Vertical Sync Phase, and With the Aid of a Vertical Phase Comparator Permits Vertical Phase Coincidence of Sync Generators With a Simple Manual Control.

by C. J. AUDITORE, TV Facilities Engineer, WOR-TV

WHENEVER REMOTE PROGRAM material is used in conjunction with locally originated picture signals, it is desirable to have the remote and local vertical synchronizing pulses in phase. This is necessary in order to prevent *rolling* of the picture at the receivers, after the switch is made at master control from local to remote program material, or vice versa.

Vertical Phase Comparator

The phase difference between any two vertical synchronizing pulses can be readily determined. It is only necessary to apply a composite video signal from one generator source to the vertical amplifier of a scope, at the same time applying a negative vertical drive

(*v dr*) pulse from the other generator to the grid of the same scope. Since the *v dr* is for all practical purposes available only locally, the remote signal must be applied to the scope's vertical amplifier. If the remote signal is viewed on the scope at half-vertical sweep speed (30 cps), the vertical sync pulse will appear in the middle of the screen. The *v dr* pulse applied to the grid will blank-out the scope trace at the instant of its occurrence. Therefore, the two vertical pulses may be viewed on the scope simultaneously and in true phase relationship. Adjustment of the vertical phase of either synchronizing generator will permit bringing the two vertical pulses into coincidence, the one blanking out the other. Since the scope sweep is trig-

gered from the signal applied to the vertical amplifier, the signal applied to the grid will appear to move relative to the conventionally displayed signal, regardless of which generator phase is being shifted.

The studio synchronizing generator is usually kept fixed at some predetermined control setting because of certain synchronism requirements imposed by associated projection equipment. When the remote program feeds are originated by the station's field pickup personnel, it is customary for the field crew to adjust their vertical sync phase to coincide with the studio. Limited adjustment is built into the synchronizing generators and with a multiple-phase primary power source and power plug reversal, it is possible to obtain any vertical phase shift desired.

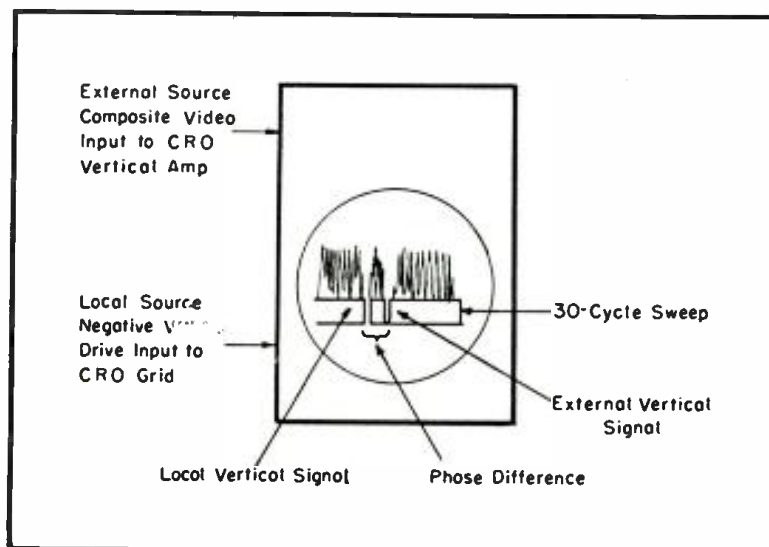

Sync Problems

Unfortunately, it is not practical to synchronize television systems which are powered from different power systems.* A common power system is a necessary reference standard of comparison. This condition will arise when taking network feeds, or when involved in remotes across the state line, for example. Although the power companies manage to keep their system fre-

Figure 1
Vertical phase comparator.

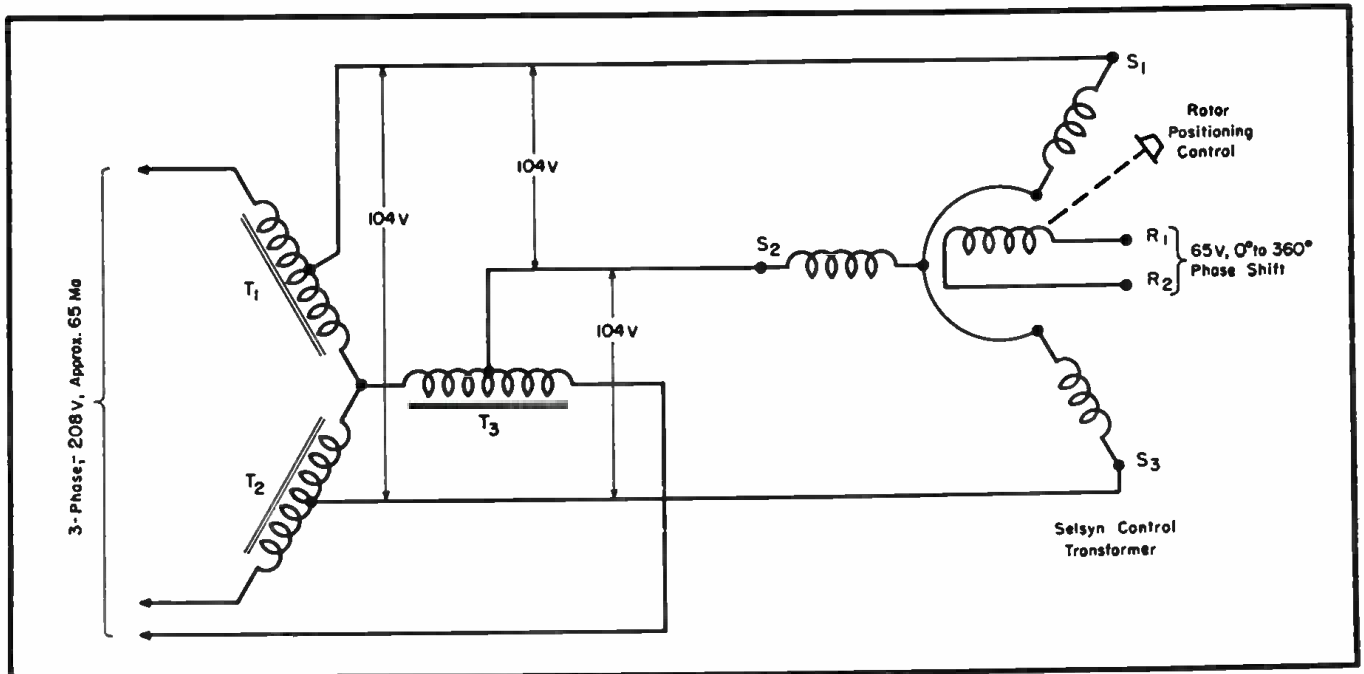

Figure 2

The selsyn phase shifter system setup. T_1 , T_2 and T_3 are step down transformers*. R_1 and R_2 terminals are connected to ext phase on the sync generator.

quency at 60 cps, within very close limits, different power systems have a lazy but constantly varying phase difference. This lack of synchronism between power systems is not easily overcome at the consumer level.

Selsyn Phase Shifter

To permit rapid adjustment of the vertical sync phase, a flexible phase shifter has been built and installed at our TV plant. With this system and the vertical phase comparator, it has been found possible to bring the sync generators into vertical phase coincidence by means of a simple manual

control. The phase shifter may be remotely located from the unit it is controlling, to lend itself to ease and convenience of operation. Furthermore, the dial associated with the control may be used to restore in a rapid manner the unit to some predetermined setting as required.

Composition of Unit

The unit consists of a control transformer type of selsyn connected to a three-phase equi-voltage power source. A control transformer type of selsyn (or synchro) is constructed with an essentially non-salient pole rotor and

a wound three-phase stator. With the stator connected to a three-phase power source, the voltage induced in the rotor will vary in phase from zero to 360° , in accordance with its displacement with respect to the stator. The amplitude of the voltage induced in the rotor will be constant regardless of its displacement. This arrangement provides an ideal source for a constant-amplitude, variable-phase reference standard for the control of a TV synchronizing generator.

Army Type Selsyn Used

An army ordnance type 5CT selsyn was employed in this application. Step-

*UTC type 41 or equivalent.

*RCA Genlock uses the synchronizing signal from an incoming remote as a reference standard of comparison for locking-in a local synchronizing generator. The incoming video signal can be used with this unit to control the line-by-line phase of the synchronizing generator at the receiving location closely enough to permit lap dissolves and superpositions of titles and slides from the studio with a remote signal.

Figure 3

Wiring changes to be made in studio sync generators. Terminals 8 and 9 are the ext phase contacts at the bottom of the studio sync generator rack, provided in the original equipment.

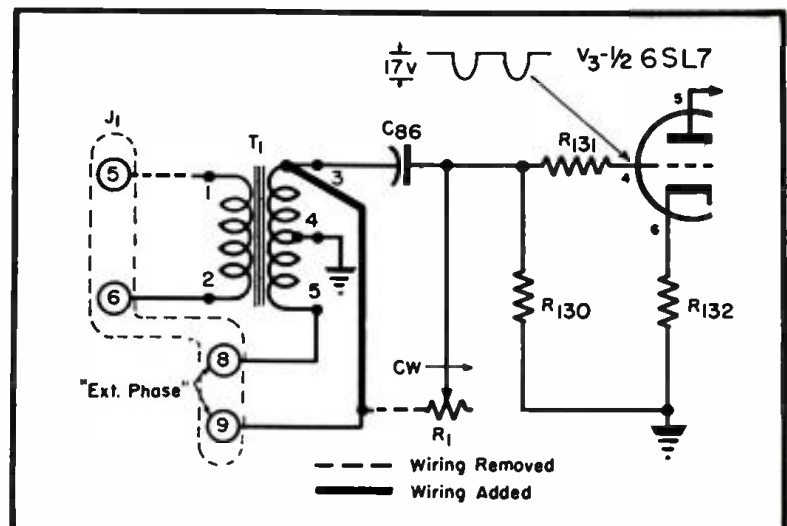

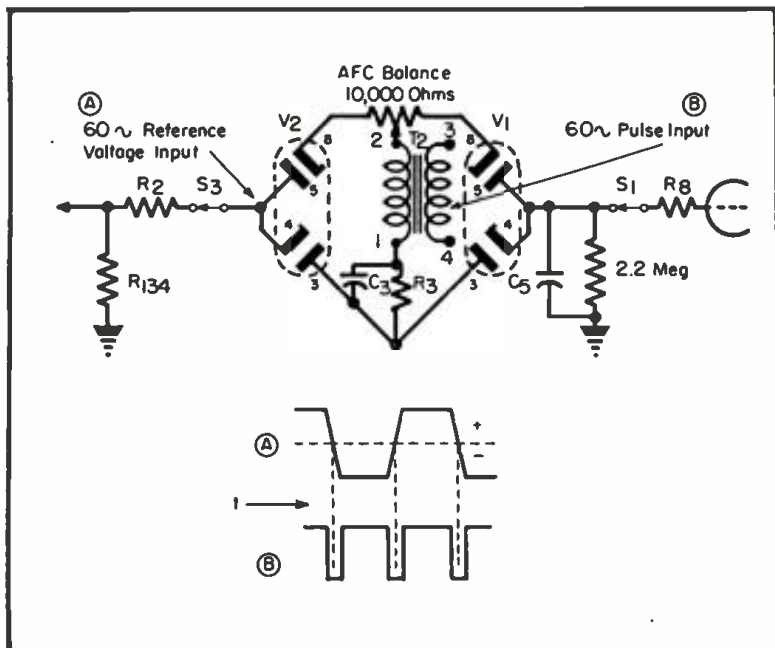

Figure 5
Lock-in bridge circuit which employs a four-arm diode arrangement.

down transformers were required to convert the available 208-volt supply to 104-volts. The stator will accept a 60-cps voltage input ranging from 90 to 120 volts. The rotor output was connected to the *Ext Phase* terminals provided at the bottom of our studio synchronizing generator.¹

Synchronizing Generator Wiring Changes

In applying this system, it is necessary to make certain minor wiring changes in the synchronizing generator. These are shown in Figure 3. In the pulse former, it is necessary to lift the lead on T_1 terminal 1; then lift the lead on the *ccw* terminal of R_3 , and finally extend this lead to T_1 terminal 3. This will effectively disable the limited-range built-in phase shift control and substitute the selsyn phase shifter.

Reference Voltage

The 60-cps reference voltage from the phase shifter is applied to the clipper tube V_3 . The input to this stage must be of the correct amplitude to provide proper clipper action. The center-tapped secondary of transformer T_1 is a convenient means for reducing the selsyn phase shifter output voltage to the required signal amplitude.

Syne Generator AFC

The function of the phase shifter can be readily appreciated after an analysis of the *afc* circuit. The 31,500-cps

¹RCA TG-1A.

master oscillator synchronizes a series of pulse-counter frequency dividers which produce all of the timing pulses used in the TV system. The output of the 60-cps pulse-counter circuit is compared with the 60-cps reference voltage derived from the *ac* power system. This comparison takes place in a lock-in bridge circuit, the output of which is a *dc* voltage, controlling a reactance tube circuit. The reactance tube circuit is a virtual inductance in the 31,500-cps master oscillator tank circuit, keeping the master oscillator on frequency.

Lock-in Bridge

The lock-in bridge is a simple four-arm diode bridge. The clipped 60-cps reference voltage will not be conducted through the bridge until it has been gated by the sync generator 60-cps pulses, applied to transformer T_2 . If the pulse gates the bridge so that exactly one-half of it occurs before the reference voltage crosses its axis and the other half occurs after the axis crossing, the output of the bridge will be zero. If the pulse is not symmetrical with respect to the reference voltage axis crossing, the bridge then produces an output of a polarity corresponding

to the direction of asymmetry. The filtered output of the bridge is applied to a reactance tube *afc* circuit which corrects the frequency of the master oscillator.

Filtering Features

In normal operation, this correction continues all of the time. However, once the master oscillator has been brought into synchronism initially, the changes are small, in the order of one part in 10,000 and average out to zero. The time constant switch, S_2 , effectively changes the amount of filtering at the lock-in bridge output, by substituting other values of resistors for R_2 . This filtering determines the speed with which the master oscillator frequency is readjusted when an error occurs.

Balance Pot Adjustments

In some of the early synchronizing generators,¹ the 10,000-ohm *afc* balance potentiometer and 2.2-megohm resistor across C_5 were left out. The balance potentiometer must be adjusted to compensate for differences in the diode characteristics. With the plug in the oscillator transformer, T_3 , rotated to its extreme *ccw* position, the *afc* time constant switch on 4 and the frequency control switch on 60-cps, the *afc* balance control should be adjusted until the voltage, measured across C_5 with a vacuum-tube voltmeter, is zero. Then the plug in T_3 should be readjusted so that the 60-cps output of the *free running* sync generator is approximately stationary on a scope sweeping at the power-source frequency.

Figure 4
Block diagram of the sync generator *afc* system.

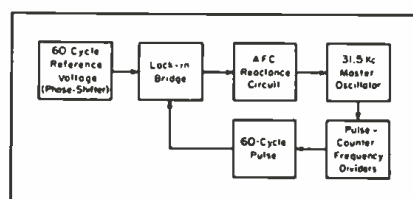



Mechanical Test Procedures, Adopted as Design Aid, Reveal Such Data as Natural Period of Vibration, Resonant Frequency Characteristics, Element Flexing, and Specific Changes Required for Dampening of Vibrations.

Checking antenna for element fatigue.

Vibration Fatigue Testing of TV Antennas

THE ART OF DESIGNING television antennas is by no means limited to the drawing board, electrical testing lab, and actual field-testing of electrical characteristics. There are certain mechanical factors to be considered, as well, factors which can reveal whether the antenna can stand the gaff of constant wind vibration, ice loads and other adverse weather conditions.

Due to the fast pace of change in new TV antenna designs, it is not always feasible to make trial installations to observe the mechanical endurance of

by **KEN LIPPERT**, Chief Engineer, Technical Appliance Corp.

new antenna types. Obviously, then, the answer must be found in some sort of accelerated test whereby, in a few hours or days, we can simulate years of rugged service. Vibration fatigue testing offers an effective means of providing this mechanical endurance information.

In these tests all the elements of an antenna array are brought to their nat-

ural periods of vibration. This is the point at which the elasticity of a member reaches its greatest flexing or movement, and during which the greatest strain is attained. Any weakness in mechanical design shows up during such tests in the form of a visual change in the distortion of the member under test, or actual fracture of the elements

(Continued on page 31)

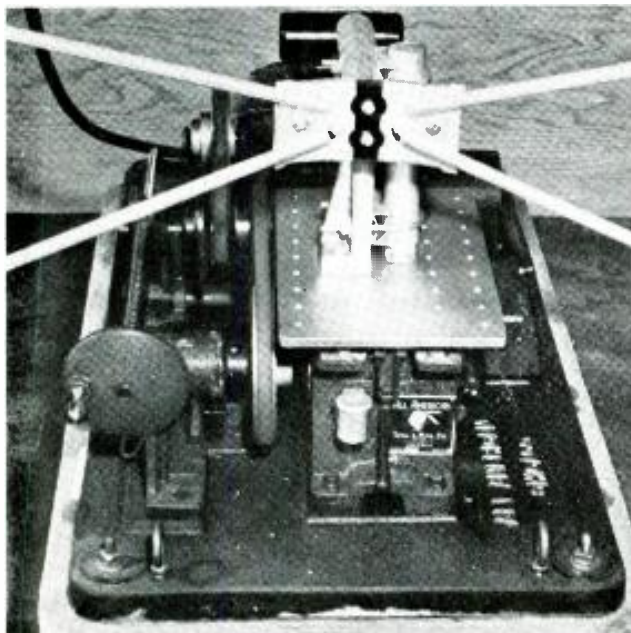

Left:
Closeup of vibration fatigue equipment during a test of an end-fire type antenna.

Below:
Another view of the fatigue test apparatus.



The Streamlining of

TV Chassis

by WYN MARTIN



Prefabricated units developed for new streamlined chassis, which have 30 per cent fewer parts and 20 per cent fewer connections.

STREAMLINED CHASSIS, featuring fewer components, less connections, a reduction in the number of tubes and simplified arrangements of parts to facilitate servicing, a goal sought by designing departments since the early days of TV, appears to have been reached in many models now coming off the line.

In the RCA chassis, for instance, there are 30 per cent fewer parts than the conventional models and 20 per cent less connections. The use of many new types of components and corresponding circuitry alterations have contributed substantially to the new approach. For instance, in the RCA sets, a new *agc* and a new 3-position switch were evolved and mounted in an accessible position on the rear of the chassis, to make it possible to adjust the *agc* control quickly for a strong or weak signal area.

To provide simple pin-point focus control adjustment, a specially designed magnet assembly was developed.

By means of a flexible cable the control was extended through the back cover of the receiver. Due to the design of the focus magnet assembly, it is possible to obtain a focus adjustment over a range of from $7\frac{1}{2}$ to 14 thousand volts. Thus a wide latitude of control exists under irregular high and low power line voltage conditions.

For centering the picture a centering or wobble plate was designed. This allows adjustment of the picture, either from side to side or in a vertical direction. This plate can be locked after adjustment by a locking screw, or by means of spring loading on some models.

In the high-voltage supply a smaller amount of capacity was included, to make the high voltage supply less dangerous due to the smaller amount of energy stored in the filter system.

Selenium rectifiers were adopted for

*From special lecture notes prepared by the commercial service section of the RCA Service Co., Inc.

the low voltage supply in 12" models, the rectifiers having been found to assure long and low cost operating life with a minimum of trouble. Employed were rectifiers rated at 130 volts *ac* and 250 milliamps *dc*.

For the *rf* input, a four circuit, switch tuned, two-tube tuner was designed as a unit independent of the receiver chassis. This type of design was found to make it possible to remove the unit as in previous models. Thus, it can be serviced and aligned independent of the chassis by using a suitable power supply source.

The *rf* unit used in the 12 $\frac{1}{2}$ " chassis employs a 6CB6 as an *rf* amplifier and a 6J6 as an oscillator and mixer tube. In the new unit the antenna input circuit has been shielded. Appearing in this circuit is an antenna elevator transformer, and a high-pass filtering section. This shielding was found to provide a great degree of freedom from stray pickup. Another feature included

Figure 1
Layout of parts normally used in a layer-built chassis, using a 12 $\frac{1}{2}$ " tube. Required are about 1,100 parts and components individually mounted, requiring about 500 solder connections.



The FM and AM traps used in a new chassis. In the AM trap, there is a 100-mmfid capacitor in the *rf* input which serves to eliminate or reduce AM broadcast interference in strong signal areas. The FM trap is adjustable from 90 to 110 mc.





IF transformers with polystyrene coil forms which are said to help provide less *rf* losses and consequent improved *rf* gain. Tests have also revealed that the use of the polystyrene forms provides higher attenuation or selectivity of the *if* trap circuits, an improved performance which was found to eliminate one *if* trap circuit in a model.

Snap-in type capacitors, used in round *if* and *rf* sections of the new type chassis, which are claimed to provide more efficient *rf* bypassing.

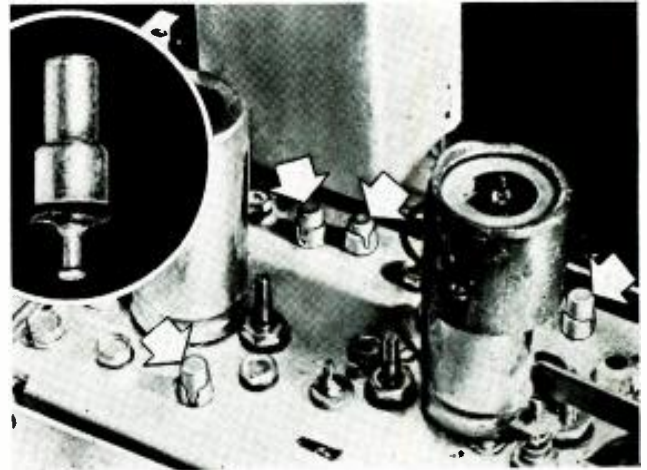

New Chassis Design Trends Feature Consolidation of Heretofore Separated Parts and Components Into Pre-Wired Assemblies, Arranged in Functional Order. Practice Found to Permit Use of 30% Less Parts and 20% Fewer Connections.

was a parallel-tuned FM (90 to 100 mc) trap, adjustable from the top of the *rf* chassis.

The 6CB6 was selected as an *rf* amplifier because it is low input conductance pentode with good low noise factor characteristics and low plate to grid capacitance. This low capacitance has been found to help minimize oscillator feed-thru which *minimizes oscillator radiation*.

The oscillator circuit and the mixer were combined in one envelope of the 6J6 dual triode. This oscillator circuit differs from previous *rf* units in that only one triode section of the 6J6 tube has been used. Stability has been obtained by using a low *L C* ratio to tune the oscillator, which helps to reduce microphonics. In addition, microphonics were also reduced by selecting the plate which does not support the getter. This is the plate or pin 1 of the tube.

Inductances have been mounted on a switch wafer for tuning channels 2 to 12. All adjustments for oscillator inductances have been made accessible from the front of the cabinet by removing the escutcheon plate. These adjustments can be made by means of brass screw studs in the inductances. A tracking inductance for all channels has also been included.

For the 12½" models a new vertical oscillator circuit was developed. It differs from that formerly used in that it

does not use the usual transformer-coupled feedback type of blocking oscillator. Feedback has been accomplished by coupling the output from the vertical sweep output circuit back into the oscillator input. In operation, a .047-mfd capacitor charges up through the B supply circuit and a 1,500-ohm resistor. During the positive excursion of the oscillator tube, this capacitor is discharged rapidly through the sweep oscillator tube, and a 12,000-ohm resistor.

When the capacitor discharges, the current through the 12,000-ohm unit causes a voltage to appear across it, so that the capacitor never discharges to zero. At the instant the grid of the sweep oscillator goes negative and cuts off the discharge of the capacitor, the grid of the vertical sweep output jumps from zero to some positive value due to the termination of the voltage drop across the 12,000 ohms. This suddenly raises the grid of the vertical sweep output tube from near zero at the end of the discharge cycle, to a positive value determined by the charge remaining on the capacitor. A .0047-mfd capacitor, a 470,000-ohm fixed unit and a 1-megohm vertical hold control determine the recovery time of the sweep oscillator. During the positive portion of the cycle on the grid of the sweep oscillator, the capacitor acquires a negative charge

(All illustrations courtesy RCA)

which leaks off through the resistances. The rate of this discharge determines the rate at which the sweep oscillator recovers and will again be ready to fire.

The use of this type of circuit was found to eliminate the need for a vertical blocking transformer, thus simplifying servicing.

Low Voltage Supply

As cited earlier, many innovations were included in the low voltage supply. In both circuits the bias voltage supply has been eliminated and all voltages are measured with respect to ground. This design, it was felt, should simplify servicing since it removes the necessity for a great number of filters and for a bleeder resistor employing a large number of taps.

The electrostatic shield in the transformer, which prevents radiation from the horizontal circuit from being fed directly into the line, has been found to be quite important. If no shield were present, the transformer would couple the 15-kc pulses from the high voltage supply, into the power line, which would then create interference on broadcast receivers within a wide range. Careful attention has also been paid to the insulation between windings. In the system used in these chassis, a large pulse of voltage is present at the cathode-filament pin of the damper tube. If

(Continued on page 31)

Tube Production Line



TV picture tube production at the Ottawa, Ohio, plant of Sylvania. At left, removing an assembled tube, which is ready for automatic exhaust and processing.



Left:

To assure maximum dependable performance in television sets, operators check every tube coming off the production line by making precise measurements of all electrical characteristics and light properties of the screen. In addition, random samples taken from each lot are given a 100% quality check. Final double check, after the tubes are cartoned, includes test of vacuum, emission and inspection for physical defects before the lot is released for shipment. Here, the operator is checking cathode activity and process quality.

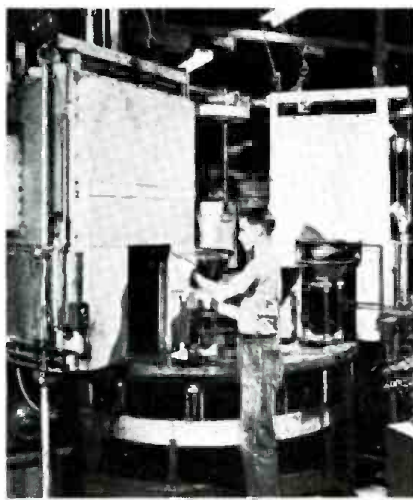
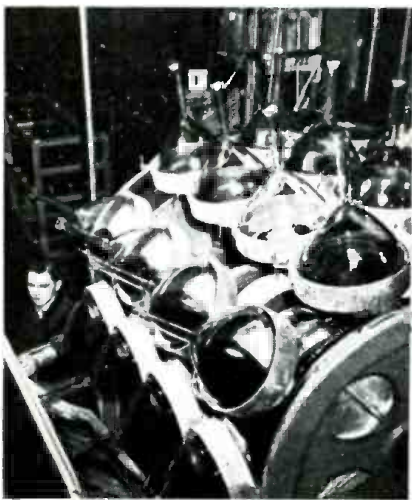

Extreme Left:

A TV picture-tube settling operation. After the tube screens have settled on the conveyor the liquid is automatically poured off and the bulbs are conveyed to a dryer. Foil caps are placed over the bulb necks to prevent possible contamination by airborne dust. This section of the plant is fully air-conditioned to assure controlled temperature and humidity conditions for uniform screens.

Left:

Automatic sealing of the tube's glass face plate to the metal cone on high-speed rotary equipment. During the operation, the metal cone and glass face plate are sealed together and tempered by passage through an oven. In this view, operator is removing the completed bulb assembly, the face of which will be screened and further processed before the electron gun is sealed.

Techniques

Right:

Views of tube production at RCA plants in Harrison, N. J., and Indianapolis, Ind. At right, a typical check method used during tube processing.



Right:

A tap test of miniatures for loose elements, in which the operator uses a soft hammer to strike the tube repeatedly while checking its operation.



Right:

Spot-welding leads to mount elements in the manufacture of miniatures.

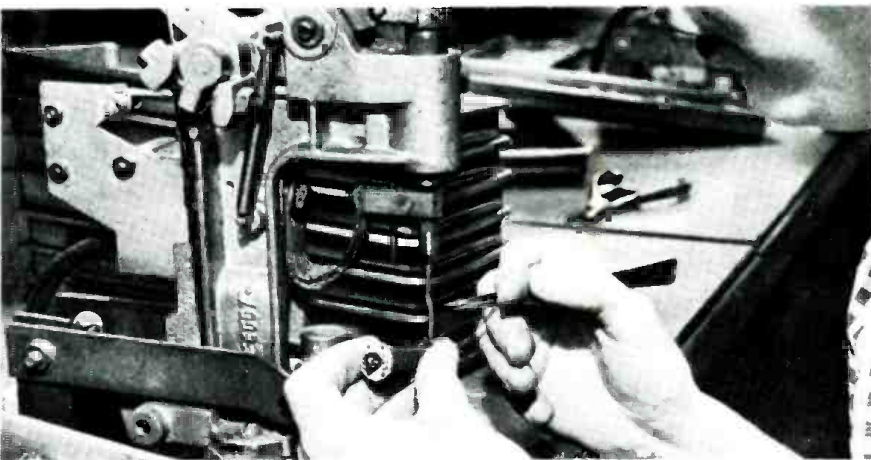

Right:

Assembling elements in miniatures on the production line at the Indianapolis plant.



Coverage of Standard-Frequency

Report of Observations of Transmissions from 400-Watt Experimental Station WWVH, Maui, T. H., Operating at 5, 10 and 15 Mc, With Receiving Points at Several Dozen Locations in U. S., Alaska, Australia, China, Japan and Islands in the Pacific Ocean. Results, Plotted, Present Accurate Picture of Reception, With Respect to Frequency, Time of Day, Season of Year, and Sunspot Conditions.

IN NOVEMBER, 1948, the Central Radio Propagation Laboratory of the National Bureau of Standards began operation of an experimental 5, 10 and 15-mc standard-frequency station, WWVH, on the island of Maui, Territory of Hawaii. Purpose of the station was to provide standard radio frequencies, time announcements, standard time intervals, and standard musical pitch for the Pacific area, in much the same manner as WWV at Beltsville, Maryland. The procedure set up provided for the three carriers and all modulation to be interrupted for periods of four minutes, immediately after each hour and each half hour and for periods of forty minutes beginning at 0700 and 1900 *gct*. These interruptions were prescribed to permit operation of automatic ionosphere sounding equipment at WWVH, to compare daily local frequency standards at WWVH with broadcasts from WWV, and to do such servicing as might be required.

Radiating approximately 400 watts at each frequency, as compared with 8 or 9 kw at WWV, transmissions have provided and are providing vital data to show the increase in standard frequency coverage and whether simultaneous reception of WWV and WWVH will or will not seriously interfere with use of the standard frequencies and time signals.

Reports of reception of WWVH alone and of WWV and WWVH together have been quite numerous as the result of the cooperation of such agencies as the Department of the Army, Depart-

ment of the Navy, U. S. Coast Guard, FCC, CAA, and others. Such procedure for obtaining information on coverage and utility of standard frequency broadcasts has been utilized previously in the case of the first 5-mc² transmissions and again in connection with 5, 10 and 15-mc³ transmissions in this country.

Reception Reports

The project has thus far resolved itself into the assembly and interpretation of a great many reception reports given in several ways from many areas. The observers have ranged all the way from inexperienced persons who did not record the place at which observations are made, to experienced engineers accustomed to making radio measurements.

A large number of reports were received from the Chief of Naval Operations and included observations made by Navy communication stations and the Pacific Fleet. Some of these reports were from China, Japan, the Philippines, and other Pacific islands from which few reports of standard frequency reception had previously been received. These reports covered much

of the period from March 7 through April, 1949, and were given in terms of signal intensity on the QSA5 scale.

A second set of reports was received from the Department of the Army, the U. S. Coast Guard, and the FCC on report forms provided by the Central Radio Propagation Laboratory. These forms enabled the observer to give his estimate of reception of WWVH and whether or not it improved the standard frequency service at that location. This type of report, while useful, did not lend itself to quantitative analysis, as did reports based on the QSA scale.

A third small group of reports gave numerical data on reception of both WWVH and WWV in Alaska and Australia. A similar set of data was received from the Navy for a location in California.

Discussion of QSA5 Scale Reports

The reports submitted by the Department of the Navy were from a large number of Naval establishments on the west coast, the islands of the Pacific Ocean, China, and Japan. Many very complete sets of data were furnished showing observations on the transmissions of WWVH at regular times, often

¹Lester, G. H., *Experimental Standard-Frequency Transmitting Station WWVH*, COMMUNICATIONS, September 1949.

²Hall, E. L., *Some Data Concerning the Coverage of the Five-Megacycle Standard Frequency Transmission*, Proc. IRE, May, 1935.

³Data were not published.

Figure 1
Reception report form.

Form for Report to CRPL on Reception and Use of WWVH and WWV				
Name _____		Address _____		Place of Observation _____
Type of Antenna _____		Is WWV or WWVH used at your Location _____		
	5,000 Kc	10,000 Kc	15,000 Kc	Other Frequencies
Date, 1949				
Time, Specify Zone				
Is WWV Usable?				
Is WWVH Usable?				
When both are simultaneously received is reception usable?				
What is observed best frequency, WWV vs WWVH, ca?				
Does WWVH Make Reception at Your Location	Better?			
	Worse?			
	About Same?			
Further Comments:				

Station WWVH

by E. L. HALL

High-Frequency Standards Section, Central Radio Propagation Laboratory
National Bureau of Standards

at half-hour intervals, throughout the 24-hour period and for nearly two months duration. (March-April 1949). Other data were at hourly or other irregular intervals. The information given included the location, time, signal intensity on QSA5 scale or notation *not heard*, with other comments as to noise or station interference. A signal intensity of QSA2 or more was taken in the analysis as a satisfactory signal, but QSA1 was considered as not satisfactory and unheard.

Data for 5, 10 and 15 mc from a given location were plotted on coarse cross-section paper, with time in hours *gct* as the abscissa, the individual days being assigned successive lines above that for the first day. Satisfactory or unsatisfactory signals on a given day were indicated by a black plus sign at the corresponding times. When data were given on the half-hour or hourly basis, and some of the times had no observations recorded, the data were filled in for a gap of one or 1½ hours, if data on either side for two or three hours indicated the same reception conditions. When conditions alternated or were irregular in reception, the data were not filled in. The numbers of satisfactory and unsatisfactory signals at a given hour or half-hour were then counted from the chart for the number of days reported. The percentage of days heard or percentage usability was

readily calculated. A portion of a chart of such data appears in Figure 1a. In Table 1 appears a portion of a table of data taken from the chart of the type from which the graphs of Figures 2 to 9 were prepared.

Time GCT	5 Mc		10 Mc	
	No. Days	% Heard Usability	No. Days	% Heard Usability
0000	36	4	37	20
0100	51	8	51	36
0200	51	8	51	40
1000	51	49	51	49
2300	51	7	50	29

Table 1

Portion of table of representative reception data taken from a complete chart for the 24-hour period as reported during March and April 1949.

During the March-April, 1949, period covered by these reports the transmit-

Figures 2 A and B (right, top)

A; reception of WWVH at Imperial Beach, Calif., April, 1949 (2,400 miles, 1,840 observations, 26 days). B; reception of WWVH at Skaggs Island, Calif., March and April, 1949 (2,400 miles, 4,390 observations, 34 days).

Figures 3 A and B** (right)

A; reception of WWVH at Whidbey Island, Washington (2,700 miles, 3,900 observations, 30 days). B; reception of WWVH at Adak, Alaska (2,500 miles, 1,520 observations, 20 days).

Figure 1a

Portion of chart showing method of plotting reception data for eight days: +, satisfactory; X, unheard or unsatisfactory; blank, no observation.

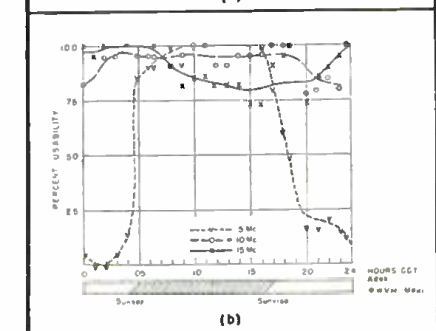
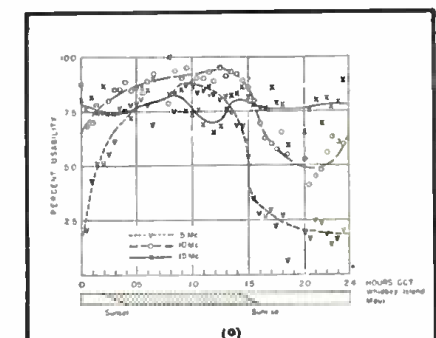
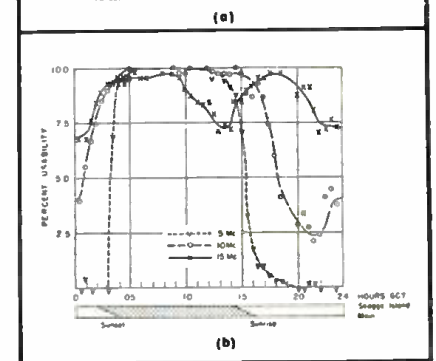
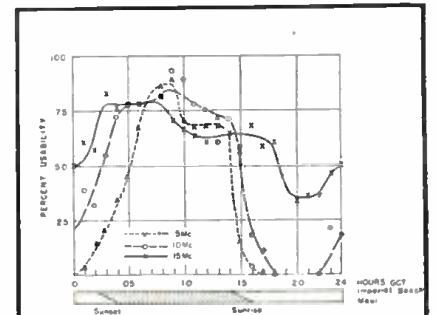
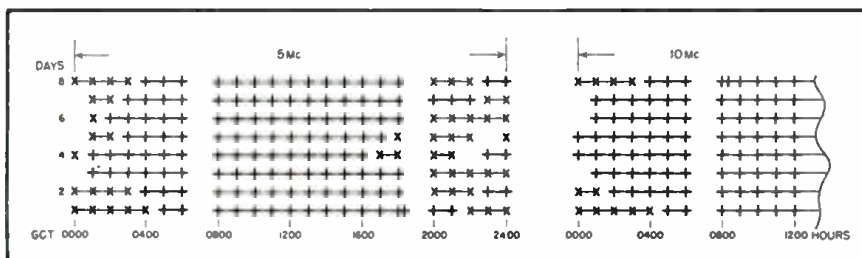

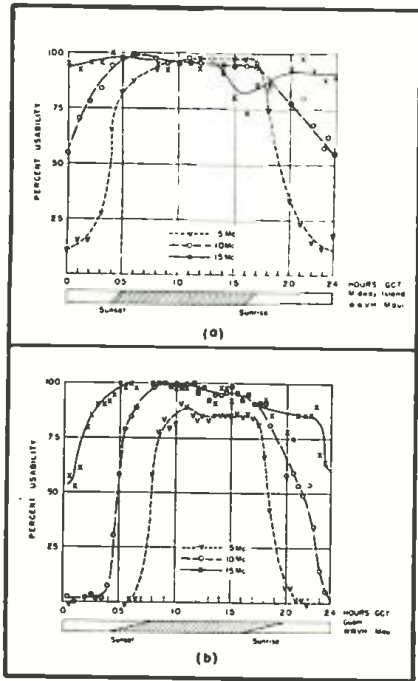

Figures 4 A and B**

A: reception of WWH at Midway Island (1,500 miles, 3,460 observations, 50 days). B: reception of WWH at Guam (3,900 miles, 6,780 observations, 52 days).

**For March to April, 1949, period.

Figures 5A and B**

A: reception of WWH at Subic Bay, Luzon, R.P. (5,400 miles, 2,240 observations, 15 mc, 51 days). B: reception of WWH at Shanghai, China (5100 miles, 1800 observation, 26 days).

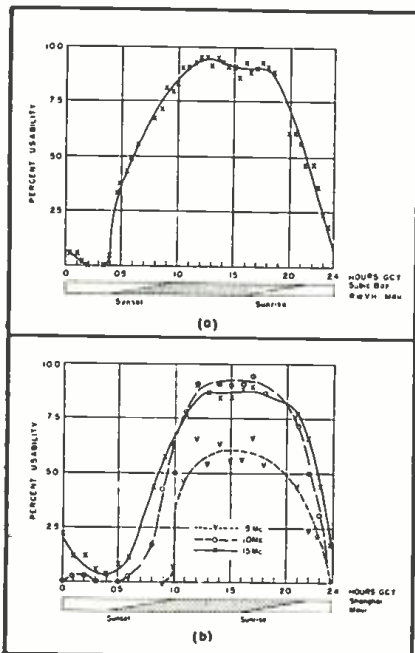

Place	Approximate Distance from Sun- WWVH (Miles)	Approximate Hour, GTC Sun- set	Observations No. Days No.	Hours, Greenwich Civil Time				
				5 mc	10 mc	15 mc		
Adak, Alaska..	2500	1700	0500	20	1520	0500-1800	0000-2400	0000-2400
Whidbey Island,								
Washington..	2700	1400	0200	30	3900	0130-1500	0000-2400	0000-2400
Skaggs Island,								
California ...	2400	1400	0200	34	4390	0300-1500	0100-1800	0000-2400
Imperial Beach,								
California ...	2400	1400	0200	26	1840	0500-1400	0300-1500	0000-1830
Midway Island	1500	1700	0500	50	3460	0400-1900	0000-2400	0000-2400
Guam	3900	2000	0800	52	6780	0800-1820	0500-2200	0000-2400
Subic Bay,								
Luzon, R. P.	5400	2200	1000	51	2240	0600-2130
Shanghai, China	5100	2200	1000	26	1810	1100-2000	1000-2200	0830-2230
Hong Kong,								
Tsingtao,								
Okinawa	5000	2200	1000	17	1510	0530-2300	0630-2200
WWVH		1600	0400

Table 2
Time for most reliable reception of WWH. March-April, 1949.

ters at WWH were off the air several times for extended periods owing to power failures and other accidental causes in addition to the 40-minute silent periods at 0700 and 1900 GCT for comparing the local frequency standards with WWV transmissions. Data for these times, if given, were discarded as WWV signals were probably heard at these times.

Data representing about 30,000 entries were prepared from the following localities: Adak, Alaska; Whidbey Island, Washington; Skaggs Island and Imperial Beach, California; Midway Island; Guam; Subic Bay, Luzon; Shanghai; Tsingtao; and a combination of localities including Shanghai, Tsingtao, Hong Kong and Okinawa.

Under the charts of percentage usability, the approximate times of sunrise and sunset at the particular location and at station WWH are shown in *Greenwich Civil Time*.

The curves of percentage usability for the three frequencies and various localities were derived from the data submitted, which covered various periods from 17 to 52 days during the two-month period mentioned. The percentage usability values plotted should be considered only as representative. If more data had been received for some of the shorter periods showing either satisfactory reception or no reception for a larger number of days, the percentage usability might have been different. It is believed, however, that the curves give a good picture of reception with respect to frequency, time of day, season of year and sunspot number for the locality indicated. Gradual departure from these curves would be expected with changes of season and sunspot number.

In Table 2 are data taken from the reports and related curves with other significant data on approximate dis-

tance from WWH and approximate times of sunrise and sunset. The hours were tabulated for which the data indicated 50% or higher usability and thus show the time of most reliable reception of WWH for March and April 1949. The hours of sunrise and sunset at the receiving location and at the transmitter are seen to have a definite effect upon the percent usability, as the best reception is found for an all-darkness transmission path. This is particularly true for the 5-mc transmissions. The 10-mc transmissions are seen to be usable for more time than the 5-mc transmissions. Likewise the 15-mc transmissions are useful longer than the 10-mc transmissions and may be usable throughout the 24 hours at distances up to 3900 miles (Guam). The reports from China indicated that reception is greatly handicapped at times by excessive static and other interference. Data from Tsingtao, China, for 20 days yielded about 4½ hours in 24 when the percentage usability was 45% or higher.

Discussion of CRPL Form Reports

The second type of report was submitted on a form such as is shown in Figure 1. The form was intended to give useful information on reception and use of stations WWH and WWV on 5, 10 and 15 mc. In a few cases there seemed to be confusion in the marking of the various spaces resulting in contradictory information. Such markings were not used or were revised to agree with the non-contradictory portion of the report. The entries on the reports were counted for the three possibilities of *better*, *worse*, *about same*, for the question, "Does WWH make reception at your location....."

[To Be Continued]

Production Aids

'Scope Tracer

AN OPTICAL POSITIONING device that permits tracing of cathode-ray patterns of a repetitive nature directly on graph paper, is now available. The use of the tracer for viewing oscillograms is said to increase accuracy by elimination of parallax caused by curved-face *crt* and flat calibrated scales. Projected pattern is exactly the size of the original trace.—*Oscillo-Tracer*; Robert A. Waters, Inc., Department TE, 4 Gordon St., Waltham 54, Mass.



Waters Oscillo-Tracer

Plastic TV Components

PLASTIC BOBBINS have been developed for all types and sizes of *em* and *em-pm* focus coils. Bobbins are said to eliminate the need for acetate washers and sleeves, provide complete protection against electrolysis, and permit more ampere turns in less space.

Other TV plastic products have also been produced. These include split bobbins for wire-wound deflection yokes, in widths to fit all sizes of coils; corona rings to protect horizontal output transformers against corona discharge; protective shells and covers for powdered iron and ceramic deflection yokes, furnished for all widths of iron, complete with terminal strips.—*American Molded Products Co.*, 1646 N. Honore St., Chicago 22, Ill.



American Molded plastic TV components

Coil Winding Machine

A COIL WINDING MACHINE that winds coils and solenoids up to 8" in length instead of 6" has been announced. Model is mounted on rods instead of a cast iron base. The rods are said to make possible better alignment and more flexibility because the tailstock now can be moved back and forth as well as from side to side. Features a tension bracket which can be moved to any position to suit the winding arbor. This is said to permit adjustment of spools closer or farther from the winding head.

Tailstock handle is vertical, permitting it to be moved by the operator's elbow and leaving the operator's hand free.

Bushings for the cam follow rod are hardened and ground, instead of oilite.

Cam, gears and idler forming the pattern are enclosed in front by a clear plastic window, keeping them in sight of the operator at all times. Traverse rack is driven by change gears and idler enclosed in back of the head. Traverse rack has an adjustable stop to insure return to identical starting position. Ball bearing tailstock with spring tension lever permits quick change to coil forms.

Model also winds progressive universal coils up to 4" in length and 3" in diameter, universal coils up to 3/4" in width, and *H* coils. Winds wire from 20 to 44 gauge. Cams are stocked from 3/4" to 1/16" in decrements of 1/64".

Standard equipment: 1/4 hp universal motor; foot operated speed controller; V belt drive; and double spool carrier with two adjustable oilite bearings to control wire during winding.—*Model 125*; George Stevens Manufacturing Co., Inc., Chicago 30, Ill.

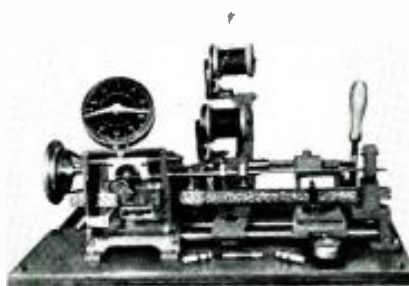

Stevens coil winder

Insulated Grommet

A METAL FORMED GROMMET completely covered with rubber has been designed for insulating blanked holes in metal to prevent cutting, chafing, shorting and rattling of wires, cables, conduit, tubing, etc., which pass through the holes.—*Arco Sta-Put series 3120*; Automotive Rubber Company, Inc., 8601 Epworth Blvd., Detroit 4, Mich.

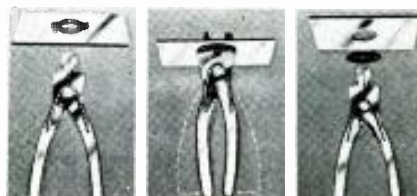

Automotive rubber insulated grommet

TV Glass Pillar Gun Fusing Machine

A UNIT FOR SEMI-AUTOMATIC GLASS GUN fusing has been placed on the market. The only manual operation required is said to be insertion of the gun parts and removal of the assembled gun from the spring collect. Unit is said to require only gas, oxygen and electrical connections to prepare it for production. Will turn out 150 to 200 guns per hour and is adjustable to rods of various lengths.

Remote control is used in this semi-automatic unit to operate the application of preheated glass rods. Positioning of glass rods for heating is a manual or hopper fed operation.—*Tri-Kris Company, Inc.*, Box 641, Walnut and Cleveland Streets, Lansdale, Pa.

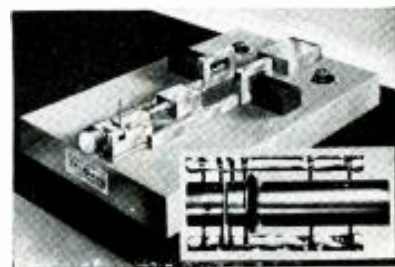

Tri-Kris pillar gun fusing machine

Plastic-Metal Screw

FASTENERS featuring a serrated metal core which has been extrusion-coated with a thermoplastic material, have been developed. The type of core and plastic used depends entirely on the use to which the screw will be put. After the extrusion process the resulting composite rod is cut in an automatic screw machine to form accurate threads and a strong head. The metal core runs the entire length of the screw and furnishes most of the screw strength. The plastic exterior is said to give the screw all of its extra insulating and sealing qualities. The metal core carries the torque applied by a screw driver or other driving instrument.

Standard sizes available from stock range in diameter from No. 8 to 1/2" with cellulose acetate insulation; from No. 10 to 3/8" with polyethylene; from No. 8 to 3/8" with cellulose acetate butyrate; and, from No. 8 to 1/2" with ethyl cellulose insulation.—*Forman Insulating Screw Corp.*, 401 Broadway, New York 13, N. Y.



Farman insulating screw

TV Parts and Accessory Review

Locking Type Shaft Molded Pots

TWO-WATT MOLDED composition potentiometers with linear taper are now available with a short screw driver shaft and locking nut.

Has a solid-molded resistance element, heat-treated under pressure, which is said to be unaffected by heat, cold, moisture, or length of service. The terminals are imbedded in the resistance element, and all parts are corrosion resistant. Unit is said to have a low noise level, smooth taper, and high load-carrying capacity.

Available in sixteen stock resistance values from 50 ohms to 5 megohms. The unit is 1 1/16" in diameter, and extends 9/16" behind the panel. A *sps*t switch, to be attached to the back of the control, can be supplied extra.—Type AB; Ohmite Manufacturing Co., 4974 W. Flournoy St., Chicago 44, Ill.



Ohmite potentiometer

Air-Spaced Feedline

TV LEADIN, with 80% of the dielectric web between wires removed, has been produced.

Can be used with standard insulators. Lead said to permit taut pulling without danger of bringing wires close together.

Lead is composed of weather resistant polyethylene. Nominal dimensions are .375" x .083". Specifications call for use of two 7x28 conductors. Packaged on reels in continuous lengths of 55', 100', 250', 500', and 1000'.—Goodline Airlead; Don Good, Inc., 1014 Fair Oaks Ave., South Pasadena, Calif.

Vitreous Enamel Capacitors

A LINE OF VITREOUS enamel capacitors, .68 to 1000 mmfd, rated at 500 *vac*, is now being marketed.

Each unit is a laminant of a low-loss ceramic dielectric and metallic silver sintered to produce a monolithic block.

The properties of the materials and the small size are said to insure low losses for all frequencies at temperatures from -55° to 200°C.—Vitramon, Inc., Stepney, Conn.



Vitramon capacitors.

Selector Switches

OVAL TYPE ROTARY selector switches are now available.

Six basic plates and three rotor types are used to construct switches having from one to three poles per deck or gang and with other mechanical and electrical details designed to match specifications. As many as 18, 9 or 6 positions may be obtained in single, double or triple pole types, respectively. These may be single, double or triple pole decks exclusively or a combination of different types.—Shall-cross Manufacturing Co., Collingdale, Pa.; Complete data in bulletin L13.

Metallized Paper Filters and Capacitors

A NEW LINE OF FILTERS for radio-noise suppression, and line of molded paper tubulars and electrolytics featuring the use of metallized paper are now available. Capacitors are said to be self-healing, and have an inherently low *rj* impedance.—Metalite capacitors and UHF filters; Astron Corp., 255 Grant Ave., East Newark, N. J.

TV Speaker With Magnetically Enclosed Motor Structure

A LOUDSPEAKER, with a magnetically-enclosed motor structure, for close mounting to the picture tube, has been developed.

Speaker uses Alnico V in a high efficiency magnetic structure. Speakers are made in sizes ranging from 5" to 12".—Rola Co., Cleveland, Ohio.

Microswitch Fitted Relays

SUB-MINIATURE TELEPHONE type relays, fitted with from one to four model ISM1 microswitches, have been developed. This construction provides an assembly 1 7/16" x 1 15/16" x 1 1/16" with contacts up to 4 form C (4 *pdt*) rated at 5 amps, 115 v 60 cps resistive load, or 3 amps, at 24 v *dc*. Maximum inrush 12 amps for 1/2 second. This relay is said to withstand better than 50 g vibration.

Microswitch is molded bakelite enclosed. Relay may be used unsealed or hermetically sealed in model M deep drawn steel can 1" x 1 11/16" x 2 5/32" high. Hermetically sealed assembly can be fitted with either plug in or solder terminals with high dielectric glass insulation. Actuating coils for either *ac* or *dc* are available.

Microswitches are said to be so mounted that the differential lever action of the armature permits lower coil power and fast positive operation.—Type MT; Potter and Brumfield, Princeton, Indiana.

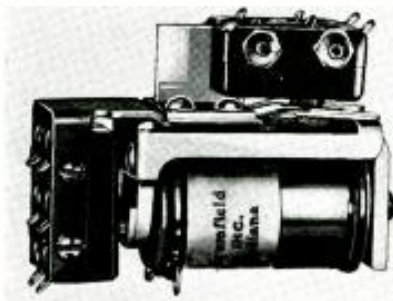

Potter and Brumfield microswitch-fitted relay

440-Volt Rectifier Cartridge

A LINE OF HIGH VOLTAGE selenium rectifier cartridges has been developed. A 440-volt *dc* type (10 ma *dc*) has a peak-current rating of 120 ma and a peak inverse rating of 1500 volts. The 440-volt rectifier is of the half wave type and is 9/16" *od* with an overall length of 1 3/8". Its voltage drop at rated load is about 25 volts, and its weight is 1/2 ounce.

Cartridges are available in either phenolic, glass or hermetically sealed assemblies from 1/4" to 1 1/4" *od*.—International Rectifier Corp., 6809 So. Victoria Avenue, Los Angeles 43, Calif.



International Rectifier selenium cartridge.

TV Antenna Mount Bracket

A TV ANTENNA MOUNT BRACKET, which can be installed on the peak of a roof, as well as the side of a roof, wall, parapet or corner of a building, has been developed.

Bracket is said to be adjustable to any position by locating a set of braces on each side of the uprights and fastening them into position by nut and bolt.

The bracket comes pre-assembled, except for side positioning braces. Standard size takes a mast up through an 1 1/2" mast, while the larger model accommodates up through a 2" mast.—Kenwood Engineering Co., Inc., 265 Colfax Avenue, Kenilworth, N. J.

HF Inductor Alternator

AN INDUCTOR ALTERNATOR has been developed to provide mobile high-frequency *ac* power from a *dc* source. Can supply 400 to 800 cycles *ac* from units with 5.5 to 230 v *dc* inputs.

AC output is obtained from a rotary inductor. The *ac* rotor and field are electrically isolated from the *dc* motor end. No permanent magnets are used for power generation. The *ac* output is claimed to be unaffected by the influence of strong magnetic fields, vibration, or aging.—Carter Motor Co., 2644 N. Maplewood Ave., Chicago 47, Ill.



Carter inductor alternator

Instrument News

Null Detector-VTVM

A NULL DETECTOR and vacuum-tube voltmeter for *ac* bridge measurements has been announced. Provides simultaneous measurement of the voltage across the unknown and the balance of the bridge. *Vtvm* has a sensitivity of .1, 1, 10, and 100 volts. Input impedance is 50 megohms shunted by 20 mmfd. Frequency range is from 20 to 20,000 cycles. Null detector gain is said to be 94 db. Has selective circuits for 60, 400 and 1,000 cycles and a frequency range of 20 to 30,000 cycles.—*Model 1210; Freed Transformer Co., Inc., 1718-36 Weirfield St., Brooklyn 27, New York.*



Freed null detector and vtvm

Long Scale Instruments

A LINE OF 28 $\frac{1}{4}$ " scale instruments has been announced featuring a spot-of-light pointer affording readings from a considerable distance.

Can be furnished with movement or sensitivity normally obtainable as microammeters, milliammeters, ammeters, millivoltmeters, voltmeters in *ac* or *dc* types, rectifier meters, thermo-type meters, *rf* meters, wattmeters, and similar instruments.

Can be calibrated to various accuracies from 5% to as close as $\frac{1}{4}$ of 1% of full scale value.

Light beam pointer is produced by light passing from a self-contained light source through a precision optical system reflected on a first-surface mirror directly upon the instrument scale.

Single instruments are 18 $\frac{1}{4}$ " high, 22 $\frac{3}{8}$ " wide and 7 $\frac{1}{4}$ " deep and weigh 34 $\frac{3}{4}$ pounds. When furnished as a dual instrument (two in a single mounting), the case measures 25 $\frac{1}{2}$ " high, 52" long and 10" deep and weighs 158 $\frac{1}{2}$ pounds.—*Cole Instrument Co., 1320 South Grand Ave., Los Angeles, Calif.*

1 $\frac{1}{2}$ " Hermetically Sealed Panel Meter

A 4 $\frac{1}{2}$ " PANEL METER, featuring a solder type zero adjuster which is said to provide adjustment without breaking the hermetic seal has been developed. A rubber gasket is included for use as a pressure seal for panel mounting.

Meter has a depth of 1 $\frac{1}{4}$ " from front of panel. Either 1% or 2% accuracy rating available. Dials are standard or specially calibrated, depending on requirements.—*Type HM 4; Marion Electrical Instrument Co., Manchester, New Hampshire.*

TV Calibrator

A TELEVISION CALIBRATOR affording the facilities of six instruments has been developed. Included in one unit are a crystal-calibrated television marker generator with dual markers for all TV frequencies; bar-pattern generator for making linearity adjustments; miniature re-broadcast transmitter for checking all TV channels; heterodyne frequency meter including amplifier and speaker; signal generator operating on fundamentals in all TV bands, and a dual crystal standard with three crystals supplied.

Instrument contains a crystal-calibrated variable-frequency oscillator, two crystal-controlled oscillator stages with three crystals, a wide-band modulator stage for internally modulating the output at audio and *rf* frequencies, and an audio amplifier with speaker.

Calibrator can be used for such applications as peak alignment, marking scope patterns, making linearity adjustments, setting local oscillator frequencies in front-ends, aligning traps, calibrating other signal generators, adjusting the frequency of small transmitters, aligning FM receivers, driving *rf* bridges, and measuring unknown frequencies.

Has an internal 4.5-mc crystal-controlled oscillator which modulates the output of the *vfo* to put dual markers on television sweep-alignment response curves.

Unit also applies triple markers of crystal accuracy on discriminator and ratio detector *S* curve patterns.—*Type WR-39B; RCA Tube Department.*



RCA TV calibrator

Volt-Ammeter

A POCKET SIZE VOLT-AMMETER 7 $\frac{1}{8}$ " long x 2 $\frac{9}{16}$ " wide x 1 $\frac{1}{8}$ " thick with seven ranges . . . 6.5/13/26/65/130 amperes and 150/600 volts, is now available.

Has a split-core transformer which will handle conductors up to 1 $\frac{1}{8}$ " in diameter. The transformer core is permanently insulated with a molded plastic cover which is said to be capable of withstanding 5,000 *v ac*.

Case and scale window are molded in one piece of impact-proof plastic. The movement is a D'Arsonval jeweled movement with alnico magnet. A plastic finger trigger opens the jaws, and the selector switch is operated with a flip of the finger. The meter is said to have an accuracy ± 3 per cent of full scale.—*Type A-5-1 Amprobe, Pyramid Instrument Co., 43 Howard St., N. Y. 13, N. Y.*

VHF Impedance Bridge

A VHF BRIDGE which extends the frequency range of conventional bridge techniques up to 165 mc is now available. Instrument can be used to measure the impedance of antennas, lines, networks, and components between the frequencies of 10 and 165 mc. Overall accuracy is said to be $\pm 2\%$ for resistance and $\pm 5\%$ for reactance. Terminals are G-R 874 coaxial connectors.—*Type 1601-A; General Radio Co., 275 Massachusetts Ave., Cambridge 39, Mass.*



G-R vhf bridge

Isolation-Testing Transformer

AN ISOLATION TESTING transformer has been announced. Unit is rated at 350 watts. May also be used to correct a high or low line voltage. Three standard receptacles provide output voltages of 105, 115 and 125, with 117 volts, *ac*, from the line.—*Standard Transformer Corp., 3580 Elston Avenue, Chicago 18, Ill.*

All-Electronic Sweep Generator

AN ALL-ELECTRONIC TV sweep generator with fundamental outputs on all channels as well as output in the *if* range has been developed. A rotary switch selects the desired channel, which is swept through a range of 15 mc by an all electronic system. The instrument is also said to produce a true zero level reference baseline on the scope display. Sawtooth sweep is said to eliminate phasing problems. Amplitude modulation of the sweep signal is less than 1% per mc. Both switched and continuously variable output attenuation is provided, with maximum outputs of about 0.5 volt on 70-ohm unbalanced output and 1 volt on 300-ohm balanced output. Contains no internal marks, and is intended for use with external marker generators. A regulated power supply is provided.—*Switcha-Sweep; Kay Electric Co., Maple Ave., Pine Brook, N. J.*



Kay Electric all-electronic sweep generator

The Hazeltine Color Tests

Extensive Probe of Color Systems Reveals That Dot-Sequential Method Offers Most Attractive Approach to a Solution of Current Problem, Affording Effective Use of the Essential Mixed-Highs Principle. Study Also Discloses That Significant Improvements Are Possible by Using a New Sampling Technique Involving a Constant-Luminance Treatment.

by P. B. LEWIS

COLOR TV RESEARCH, now in its most active stage, has produced many significant developments, particularly in bandwidth conservation. Whereas originally bands of 12 mc and higher were prescribed for color transmissions, persistent probes revealed that substantial success could be achieved on 6 mc, with several systems being suggested for the project.

One 6-mc, or 4-mc effective bandwidth method, found to be quite effective, has been the dot-interlace, which may take the form of introducing additional component frequencies in the many narrow unused gaps in the band which the normal signal occupies. The effect of such an added signal has been found to be two-fold; it can add to the total amount of useful information transmitted by the signal, and it produces spurious patterns in the received image, patterns which do not contribute usefully to the image structure. Tests have revealed that the perceptibility of the spurious pattern can be somewhat minimized by proper system and apparatus design, and by reducing the amount of extra information which is added to the signal by the dot-interlacing principle.

In studying the dot-interlace approach at Hazeltine, it was found that if the technique is applied and if some advantage is taken of the mixed-highs

principle,¹ it is possible to produce a picture in which the resolution is not degraded from that of a corresponding monochrome system. Although color has been added, a spurious pattern of moderately perceptible character results.

In one approach, which has been mentioned by RCA in one of its reports to the Commission but which according to Hazeltine has not been demonstrated, the mixed-highs component of the signal in the receiver has been separated from the composite signal prior to the color sampling operation. As a consequence, the spurious pattern associated with the sampling has been found to be limited to edges and strongly colored areas rather than being apparent throughout the picture.

It was also found that other proposed systems transmit information which is useless to the viewer; since these systems have limited information-transmis-

sion capacity, the transmission of any useless information must directly subtract from the useful information which can be transmitted. This consideration indicated that there were ultimate potentialities of the dot-sequential system, exceeding those of the other systems.

In view of this interesting condition, it was felt that these possibilities should be explored.

Work in this direction at the Hazeltine labs has resulted in the evolution of certain new principles, which deal with the problems of decreasing the perceptibility of the dot pattern, decreasing the susceptibility of the dot-sequential system to beat note interference, decreasing the color cross-talk, and improving the resolution beyond that which would normally be expected with a 4-mc band.

In the new approach, a considerable change in the sampling, both at the transmitter and at the receiver, was added to the preceding form of receiver (with its shunted mixed highs). This improved method of sampling, *constant luminance sampling*, serves to arrange the sampling operation so that its output is not required to contribute any change in net brightness to the signal. This procedure has been found to affect only the hue and the saturation of the areas without altering their apparent brightness in any respect. The susceptibility of the receiver to interference in the vicinity of the sampling frequency has been found to be reduced by something of the order of 6 to 8 db. The property of the eye appears to be

(Continued on page 30)

System	Interference Frequency Relative to Carrier Frequency						Effective Overall Relative Susceptibility
	-0.75 mc	0 mc	+0.75 mc	+1.5 mc	+2.5 mc	+3.5 mc	
Standard monochrome	1	1	1	1	1	1	1
Field-sequential color	1	1	1.2	1.7	2.5	3.3	1.5
RCA dot-sequential color	1	1	1	1.1	2.5	8.3	1.6
Constant luminance dot-sequential color	1	1	1	1	1.3	3.4	1.2

System	Visual susceptibility of standard monochrome varies with frequency of beatnote. Above relative susceptibilities calculated for a viewing distance of eight times picture height, at which distance standard monochrome calculates to have the following variation in susceptibility with frequency:					
	0.75 mc	6 mc	+0.75 mc	+1.5 mc	+2.5 mc	+3.5 mc
Standard monochrome	0.0	1.0	1.4	0.81	0.35	0.16

Figure 1
Calculated relative visual susceptibility of TV systems to beat-note interference. (Standard monochrome considered as reference*)

Before Any Other Consideration

Integrity of Circulation



OF THE several factors that enter into the use of published media, the distribution of the advertisers' sales messages, as governed by the selection of media, can of itself decide the success or failure of the advertising investment. That is why integrity of circulation is the first consideration with experienced space buyers.

The emblem shown above stands for the FACTS that make it possible for advertisers to select the right media and to know what they get for their money when they invest in publication advertising. It is the emblem of membership in the Audit Bureau of Circulations, a cooperative and nonprofit association of 3300 advertisers, agencies and publishers.

Working together, these buyers and sellers of advertising have established standards for circulation

values and a definition for paid circulation, just as there are standards of weight and measure for purchasing agents to use in selecting merchandise and equipment. In other words, A.B.C. is a bureau of standards for the advertising and publishing industry.

A.B.C. maintains a staff of specially trained auditors who make annual audits of the circulations of the publisher members. Information thus obtained is issued in A.B.C. reports for use in buying and selling space. All advertising in printed media should be bought on the basis of facts in these reports.

This business paper is a member of the Audit Bureau of Circulations because we want our advertisers to know what they get for their money when they advertise in these pages. Our A.B.C. report gives the facts. Ask for a copy and then study it.

SOME OF THE AUDITED INFORMATION IN A.B.C. BUSINESS PAPER REPORTS

SEND THE RIGHT MESSAGE TO THE RIGHT PEOPLE

Paid subscriptions and renewals, as defined by A.B.C. standards, indicate a reader audience that has responded to a publication's editorial appeal. With the interests of readers thus identified, it becomes possible to reach specialized groups effectively with specialized advertising appeals.

- How much paid circulation.
- How much unpaid circulation.
- Prices paid by subscribers.
- How the circulation was obtained.
- Whether or not premiums were used as circulation inducements.
- Where the circulation goes.
- A breakdown of subscribers by occupation or business.
- How many subscribers renewed.
- How many are in arrears.



TELEVISION ENGINEERING

A.B.C. REPORTS — FACTS AS THE BASIC MEASURE OF ADVERTISING VALUE



Group Subscription Plan

You Save Half of the Subscription Price if Four or More Orders, Including Your Own, Are Properly Entered on This Form

To the Publishers of

TeleVision Engineering, 52 Vanderbilt Avenue, New York 17, N. Y.

Please enter two-year subscriptions (24 issues) for each of the undersigned for which payment is enclosed at the rate of \$3.00 each. (This rate applies only on 4 or more subscriptions when occupations are given.)

Regular cost is \$3.00 for one year.

Name

Address

City..... Zone..... State.....

Occupation..... Title.....

Department in which employed

Operation Production Research

Employed by

Nature of Business.....

(State if TV Manufacturer, TV Broadcast Station, etc.)

Name

Address

City..... Zone..... State.....

Occupation..... Title.....

Department in which employed

Operation Production Research

Employed by

Nature of Business.....

(State if TV Manufacturer, TV Broadcast Station, etc.)

Name

Address

City..... Zone..... State.....

Occupation..... Title.....

Department in which employed

Operation Production Research

Employed by

Nature of Business.....

(State if TV Manufacturer, TV Broadcast Station, etc.)

Name

Address

City..... Zone..... State.....

Occupation..... Title.....

Department in which employed

Operation Production Research

Employed by

Nature of Business.....

(State if TV Manufacturer, TV Broadcast Station, etc.)

Business or professional classifications are required to complete our records. Each subscriber should write one of the following classifications in space indicated. Use separate sheet of paper for additional names.

CHIEF ENGINEER ENGINEER EXECUTIVE
PURCHASING AGENT DEPARTMENT MANAGER

State your classification if not listed.

This Group Sent In By —

Name

Address

Studio Lighting

(Continued from page 7)

been found that not only can pinpoint highlights and shadows, be measured, but every part of an entire TV set can be checked from the camera position. If the footlambert readings of the photometer show that the ratio of the brightest bright to the darkest dark is greater than the calculated brightness range of the tube or tubes being used, then it will be necessary to relight the scene. If the bright-to-dark ratio is greater than the brightness range, it will be necessary to use more floods and fewer spotlights.

Once a scene is correctly lighted, both for mood and for brightness range, it is a simple matter to calculate the proper *f-stop* opening for the camera lens. Checks made with a *video analyzer* will reveal the saturation number for the image orthicon in the camera, and the fact that at that particular stop opening the tube will saturate at 20 footlamberts; the value of wedge No. 6 in the analyzer's gray scale. Illumination checks made with the *photometer*, will disclose the footlambert value of the brightest highlight. By balancing one against the other it is possible to obtain the proper *f-stop* opening for those conditions of illumination.

As an example, let us suppose that we are using matched tubes on a multi-camera show whose saturation, *f*, numbers are 8. We then know that at *f/8*, the tubes will saturate with 20 footlamberts of reflected illumination. However, suppose in the scene as we have illuminated it, having been careful to keep well within the brightness range ($30/C^2$), the *photometer* shows that the brightest highlight has a value of 40 footlamberts, or twice the amount of light that will saturate the tubes at *f/8*. Obviously, the cameras must be stopped down one additional stop to *f/11*. Similarly, if the brightest highlight has a value of 80 footlamberts, or four times the light that will saturate the tubes at *f/8*, the lenses on the cameras will have to be closed down two additional stops, or to *f/16*.

In tests, it has been found possible to light studio sets and set camera *f-stops* with this system without referring to the image on a monitor. In each case, when the illumination had been arranged according to the dictates of the *photometer*, in relation to the characteristics of the image orthicon, and the lens cap was removed, no lighting or *f-stop* changes were found to be necessary to improve the final image. When changes were made, they only served to lower the picture quality.

Personals

Ira Kamen has been appointed director of TV development and promotion for the Brach Manufacturing Corp., 200 Central Ave., Newark, N. J. Kamen was formerly manager of the TV department for Commercial Radio Sound, RCA distributors in the New York, New Jersey and Connecticut areas, where he designed the TV master system layouts for many hotels, including the Commodore, Park Lane, McAlpin, and Shelton, and numerous apartment houses in N. Y. and N. J. Prior to his affiliation with Commercial, he was director of electronics of Conlan Electric, consulting engineer to Intra-Video, Workshops Associates, and others. During the war, he served as a supervisor professional radio engineer with the Navy Department. He is co-author of the book, *TV-FM Antenna Installation*.



Ira Kamen

Donald E. Smith, formerly an engineer for the electronics division of Sylvania Electric Products Inc., Boston, Mass., has been transferred to the renewal tube sales department of the Sylvania radio tube division. He will be located at St. Louis, Missouri.

John A. Green, for nine years an electrical engineer with the Collins Radio Company, Cedar Rapids, Iowa, and for the past several years head of their broadcast engineering department, has established the John A. Green Co., manufacturers' rep and the Equipment and Service Co., consulting engineers and electrical manufacturers, at 6815 Oriole Drive, Dallas, Texas.



John Green

Robert C. Sprague, RTMA president, will address the annual Fall Meeting, of members of the IRE and the RTMA Engineering Department, on Oct. 31 at The Hotel Syracuse, N. Y.

William E. Herrmann has been appointed manager of sales of the laboratory products section of General Electric's special products division.

C. J. Biver has been appointed commercial engineer of the central region for General Electric's tube division. **J. L. Brown** will continue in his present capacity as central regional sales manager for equipment tubes. Biver will headquarter in Chicago.

Francis X. Rettenmeyer has joined Philco as executive engineer to assist in the engineering administration of the company's government and industrial electronic program. Rettenmeyer, for ten years was with RCA as chief receiver engineer in the home instrument division, and during the past five years served as chief engineer for Federal Radio and Telegraph.



F. X. Rettenmeyer

Robert L. McNelis, formerly manager of the Sylvania New York warehouse, has been promoted to distributor sales rep for the radio tube division of Sylvania Electric Products Inc. McNelis will serve the metropolitan New York sales division in the distribution of radio and television receiving tubes, test equipment and electronic products, and will make his headquarters at 1740 Broadway.



R. L. McNelis

Nelson W. Wells has been appointed sales manager for the Television Equipment Corp. He will direct the sales program for the firm's new TV camera chain, electronic blackboard, scope, telebooster, etc.



N. W. Wells

Walter Albert Buck has been elected vice president and general manager of the RCA Victor Division. Admiral Buck had previously been president of Radiomarine Corporation of America, which he joined upon his retirement in 1948, as a Rear Admiral of the U. S. Navy.

Myles Spector has joined the National Electronic Mfg. Corp., Long Island City, N. Y., in a sales engineering capacity. He is the son of Samuel J. Spector, president of the firm.

Willard R. Barrett has been named sales manager for the plastics division of General Electric.

Industry Literature

Electro-Voice, Inc., Buchanan, Michigan, has published a bulletin, No. 158, describing a self-tuning Tune-O-Matic television booster. Booster is described as permitting operation from the television receiver controls only.

Insulation Manufacturers Corporation, 565 West Washington Boulevard, Chicago 6, Ill., has released an 8-page booklet listing electrical insulation products handled by the corporation. All products are listed in alphabetical order.

National Bureau of Standards, Washington 25, D. C., has published a new booklet, *Colorimetry*. Booklet describes the standards and measurement methods developed by the Bureau, giving the basis for each technique and showing clearly how one method supplements the other. Chapters cover the standard observer; illuminants and coordinate system; small-difference colorimetry; material standards of color; one-dimensional color scales; and general methods. Book, prepared by Dean B. Judd, is priced at 30 cents a copy, and is available from the Superintendent of Documents, U. S. Government Printing Office, Washington 25, D. C.

The RCA Tube Department has published a receiving tube booklet, form No. 1275-E, which covers more than 450 RCA receiving tubes and picture tubes, including more than 50 new RCA tube types.

Characteristics and base diagrams are given for each tube type. A classification chart is also included to permit quick determination of the type designations of receiving tubes, according to their functions and filament or heater voltages.

Measurement Corporation, Boonton, New Jersey, has announced the publication of the second issue of *Measurements Notes*, a four-page brochure, which describes the measurement of the impulse noise susceptibility of receivers.

Cornell-Dubilier Electric Corp., South Plainfield, N. J., has released a 32-page catalog, No. 410, on its line of Powercon vibrator converters.

Twenty-two models in five different types are covered: *dc* and *ac* converters, phonomotor and record player converters, battery charges and eliminators, *dc* to *dc* converters, *dc* and *ac* (mobile and fixed station) dual-operation converters. Presented, too, is a nine-page manual on the use of vibrator converters. Another feature is a Powercon selection guide, in the form of a table for quick reference.

United Transformer Co., 150 Varick St., New York 13, N. Y., has published a 28-page illustrated catalog, No. 500, listing transformers, reactors and filters, and featuring application and spec data, and amplifier circuits, curves and useful charts.

Standard Transformer Corp., 3580 Elston Ave., Chicago 18, Ill., has published a 20-page catalog of transformers and related components for radio, sound and industrial applications. Catalog lists complete electrical and physical specifications of more than 400 part numbers. Also included is a complete price list and set of handy charts.

It's EASY to install "Payroll Savings"

... and 20,000 companies' experience proves it pays!

If you've put off installing the Payroll Savings Plan in your company because you feel it would be "a lot of work," then this advertisement is certainly for you! Because it's really very simple to give your employees the advantages of investing in U. S. Savings Bonds the easy, automatic "Payroll" way.



HERE'S ALL YOU NEED TO DO

Appoint one of your top executives as Savings Bond Officer. Tell him to get in touch with your State Director, Savings Bonds Division, U. S. Treasury Department. Here's what happens . . .

The State Director will provide application cards for your employees to sign—plus as much promotional material and personal help as necessary to get the Plan rolling in your company.

Those employees who want Savings Bonds indicate on the applications: how much to save from their pay; what denomination of Bonds they want; and the inscription information to appear on the Bonds.

Your payroll department arranges to withhold the specified amounts, arranges to get the Bonds, and delivers them to the employees with their pay.

The Bonds may be obtained from almost any local bank or from the Federal Reserve Bank or may be issued by the company itself upon proper certification by the Federal Reserve Bank or Branch in the company's District.

THAT'S ALL THERE IS TO IT!

In case you're skeptical as to how many of your employees would like to have Payroll Savings, canvass your plant—and be prepared for a surprise. (Remember that pay-check withholdings for Bonds are *not* a "deduction"—the employee takes home his Bonds with his pay.) One leading manufacturer, who had professed little faith in the Plan, found his eyes opened when he asked the people in his plant whether they would like to obtain Bonds in this way. Within only six months after he installed the

Plan, half his employees signed up. A prominent aircraft manufacturer, whose company had used the Plan for some time, was not aware of its potentialities until his personal sponsorship increased participation by 500% among his company's employees.

THE BENEFITS ARE BIG— FOR EVERYONE

The individual employees gain security—they know that the Bonds they hold will return \$4 for every \$3 at maturity. The company gains from

the resultant increased stability and efficiency of its workers. The whole nation gains because Bond sales help stabilize our economy by spreading the national debt and by creating a huge backlog of purchasing power to boost business in the years ahead.

Is it *good policy* to deprive your company of Payroll Savings—even one more pay day? Better at least have a talk with your U. S. Savings Bonds State Director, get the answers to your questions, and *know for sure*.

The Treasury Department acknowledges with appreciation the publication of this message by



TELEVISION ENGINEERING

This is an official U. S. Treasury advertisement prepared under the auspices of the Treasury Department and The Advertising Council.



Officers

LEE DE FOREST, *Honorary President*
WILLIAM J. MCGONIGLE, *President*
E. N. PICKERILL, *2nd Vice President*
WM. C. SIMON, *Secretary*
R. J. IVERSEN, *Assistant Secretary*
C. D. GUTHRIE, *Treasurer*

Board of Directors

GEORGE H. CLARK CAPT. FRED MULLER
A. J. COSTIGAN HARADEN PRATT
C. D. GUTHRIE WILLIAM C. SIMON
WILLIAM J. MCGONIGLE GEORGE E. STERLING

Personals

THE NEW MEMBERSHIP FRONT reveals that a real oldtimer has joined our ranks, Fred Burgess. . . Burgess, who was born in England, started his *wireless* career back in '19 when he pounded brass on ships operated by Siemens Brothers of London. He was at the key for this company for ten years and in '29 shipped out aboard a freighter operated by Marconi of London. A little later he transferred to Canadian Marconi of Toronto, where ship and land assignments were held. In '30, he joined the Standard Fruit Co. Subsequently Fred saw service aboard the Furness Red Cross passenger ship, and boats of the U. S. Gypsum Line. In Sept. '35, Burgess joined the United Fruit Co., with whom he is still associated. During the past fifteen years Fred has been aboard ships of the Great White Fleet cargo and passenger lines. During World War I, Fred served with the British Army, in communications. He was wounded in France. Fred has sailed under the flags of six nations: U. S., Great Britain, Honduras, Canada, Panama and Bermuda. . . Harold B. Koch has also become a VWOA man, as an associate member. Harold's career has been quite exciting. In '43, he graduated from Gallops Island and was assigned to a WSA vessel, licensed by Tropical Radio. He continued to work on board ships until '45, when he was assigned to shore duty with Tropical Radio Service Corp., where he has been since. Harold has three years to go, before he can enjoy the full privileges of a VWOA veteran member, but we are glad to have him with us as an associate. . . A report has been received disclosing that Eugene C. Cochrane, senior field inspector of the New York FCC office, will retire in September. Gene, during his many years with the Government in radio at the New York office has probably met more ship-board radio operators than any man in



Veteran ops at work: Tropical Radio experts George Mathers, at bench, and Ralph K. Davis. Both are members of the service units of TR, in the New York branch. Davis is chief inspector at the branch office.

the world. Oldtimers will indeed miss Gene Cochrane's frequent visits of inspection aboard ship. His is a job well done and his retirement well earned. . . Ye secretary has just returned from a short vacation at his summer home at Rocky Point, Long Island, within sight of RCAC's towers. . . In a note from A. B. Angle from Miami we learned that on Nov. 4, 1949, he celebrated his twentieth year of continuous service with Tropical Radio, some of which had been spent aboard ship and the remainder at WAX. AB has been for the past 27 years a 600-meter man. He hopes to put in another 20 years, the latter on 500 kc, though. Incidentally, AB was a U. S. Coast Guard radioman during World War II. . . Larry Bennett, now with the Mass Radio School as purchasing agent, told ye secretary that he has renewed his ham ticket after a layoff of thirty years. Call letters are W1HH. . . Lee R. Dawson, in a note from Hawaii, sends his best regards to all. Perhaps LR could set up a dinner-cruise next February with VWOA Hawaiian members. . . Frank Melville advises that he is a parts jobber with an office in Flushing, N. Y. . . T. M.

Moss, from the Peachtree state, is now with Eastern Air Lines at the Atlanta Municipal Airport. TM has been active since '35. He's an amateur; call, W4HYW. . . VWOA member H. P. Westman is quite busy these days as editor of *Electrical Communication*. He lives in West Hempstead, L. I. . . W. M. Vogt is district manager of Mackay's Galveston office. . . William D. Kelley, who is transmitter supervisor of WFBR, notes that he will soon be 50, and he longs for a trip to sea. He still holds a 1st class radiotelegraph ticket of which he is rather proud. Kelly started his wireless career back in '22, when he took his first job with the Independent Wireless Telegraph Co. In '27 he left the *ships* for a shore job at WFBR, beginning in the control room. . . Another oldtimer, Eugene J. Krusel, reports that he began his service in '13, when he started pounding brass as a ham using the call 9VQ and a 1/2 kw spark of his own design. His sea-going experience began in '26 and for two years he sailed the waters. In '28 he joined WCFL. . . Ed G. Raser told ye secretary that the Delaware Valley Radio Association's Sixth Annual *Old Timers Vite* was a real success at the Stacy-Trent Hotel in Trenton, N. J. Ed was chairman of the committee. Several VWOA members attended. . . Everyone was shocked to hear that George Schecklen was in an accident. We hope that by now he has fully recovered. . . Walter J. Simon, who is sailing aboard the Standard Oil (Esso) tanker, Birch Coulie, writes that he is enjoying the days at sea, but better still those long periods ashore. . . F. P. Guthrie has completed 26 years with RCA. . . John J. Masiello, who started in wireless back in '19, is now with the Civil Aeronautics Communication station as Facility Chief in Charge, at Pueblo, Colo. JJM saw service in the Navy during World War II, spending most of his time in the South Pacific.

RC Tuning Network

Bandspreading and

IN SETTING UP A PARTIALLY-EQUALIZED tuning system, employing the circuitry of Figure 1, two pairs of potentiometers, P_1P_2 and $P'_1P'_2$, were used. It was found that they could be either ganged mechanically on the same shaft or by means of a common driving gear. When ganged on the same shaft, it was found possible to use a 270° tuning dial without the intervening gear.

Six ten-point switch decks ($S'_1, S'_2, S_1, S_2, S_3, S'_3$) were ganged and set up for control from the front panel. These decks perform the series-single unit reversed and parallel connections, in the proper sequence, as indicated by the switch points in some of the switch decks. The characters *a, b* and *c* cor-

respond to the scales *A, B* and *C*, and the indices *1, 10, 100* and *kc* refer to the multiplier applied by these particular switchpoints. The resulting tuning resistance appears between the switch arms of the decks S'_1, S'_2 and S_1, S_2 .

The two upper switch decks, S_3 and S'_3 , place the proper multiplier capacitors, *C* and *C'* (*C* and *C'* of Figure 2), in their correct relationship to the tuning circuit. Each set of three switch points on these two decks (corresponding to the scale-selector points *a, b* and *c* of the scale-selector switch, consisting of the decks S_1, S_2 and S'_1, S'_2) were connected together, so that each pair of tuning capacitors, *C* and *C'* could cover a complete switching cycle on switch

points *a, b* and *c* or the corresponding scales *A* through *C*. Thus we have a complete decade spectrum within the tuning range, for which the instrument was designed. Consequently, the decreasing values of these pairs of tuning capacitors, for increasing frequencies covered by the set of three sub-scales, follow a pattern of decimal steps.

The smallest capacity value in the circuit, only 2.5 of the value of the next higher capacity, was attained by connecting the tenth switch point, *kc*, to the switch points governing the *C* scale, placing a tuning resistance in the circuit which is four times smaller than the tuning resistance for the *A* scale. Therefore, by making the tuning capacitors four times larger than 1/10 of the value previously in the circuit, readings can be made on the *A* scale with a multiplier of 1,000 or *kc*. An interesting advantage was gained by this approach. When the *A* scale in *kc* repre-

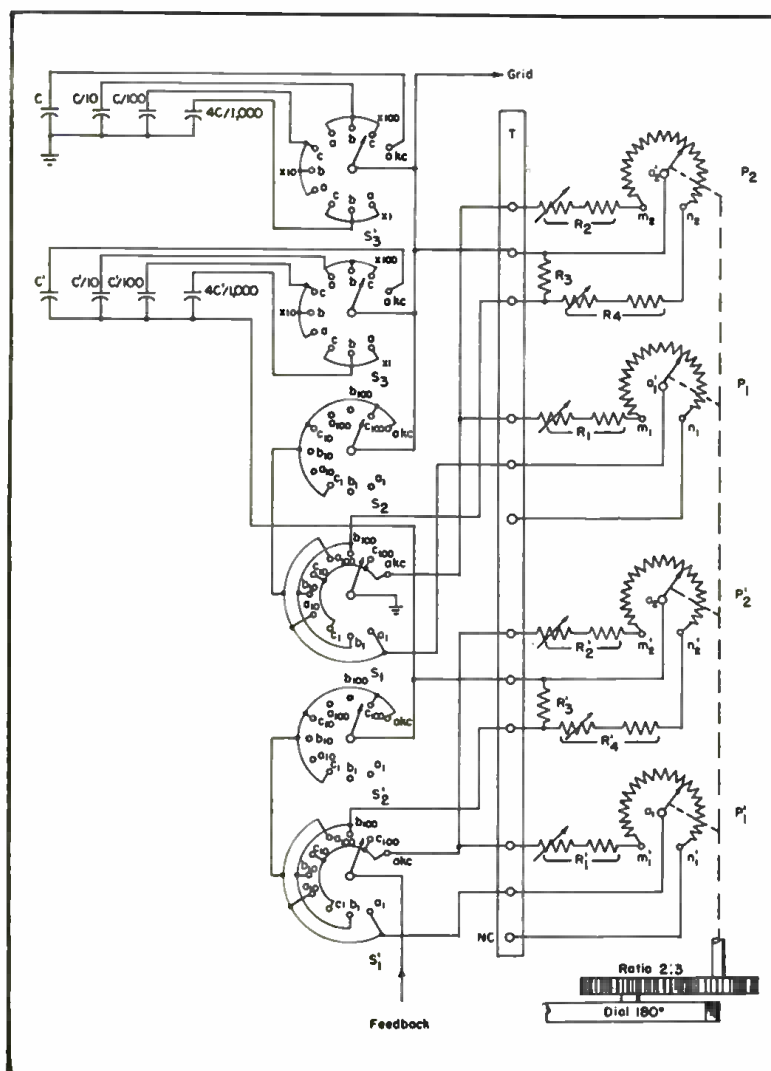

Figure 1
Continuous selector type circuit developed by the author. Ten positions afford coverage from 10 cps to 25 kc.

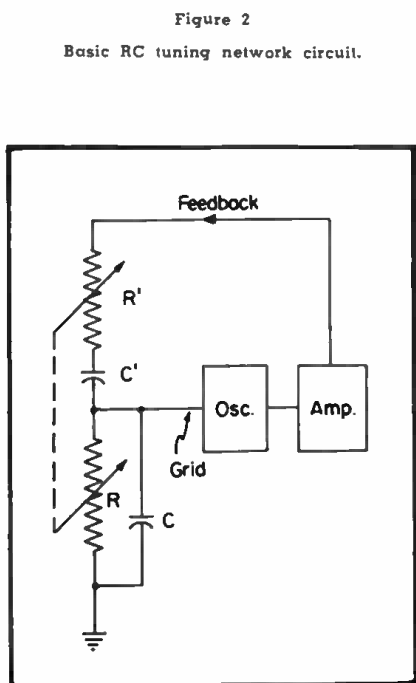

Figure 2
Basic RC tuning network circuit.

Scale Equalization

Systems, Evolved to Provide Partial Equalization and Completely Equalized Bandspreading, Simplifies Scale Reading from 15 to 15,000 cps Without Resetting of Dial.

by C. F. VAN L. WEILAND

sents the highest coverage of the instrument, the stray capacities will be small in relation to the tuning capacity, and therefore easier calibration and greater stability results.

It was stated earlier that the maximum tuning resistance equals 60,000 ohms. Therefore, when the minimum frequency to which an instrument is to tune is set at, let us say, 10 cps, we find from equation (1) that a capacitor of slightly over .25 mfd would be needed. The subsequent sets of capacitors would then be .025, .0025 and .001 mfd, covering the frequency range from 10 cps to 25 kc. This was achieved by a progressive and continuous selector arrangement using one switch knob on the front of the panel. The switch combinations can, of course, be broken up into two switches. On the first combination each one of the switch positions *a*, *b*, or *c* could be representative of a scale, *A*, *B* or *C*, and therefore a switch of three switch positions, performing the function of this scale selector, could take its place. The decks, *S*, *S'*, could be replaced with a two-pole multiplier switch having as many switch points as there are multipliers required.

Completely Equalized Bandspreading

It was found that the foregoing method did not eliminate scale crowding. A method, which would provide distribution of the scale divisions more evenly over the three scales was therefore sought. Such conditions as the 2.5 : 1 ratio, imposed by the previously described scale structure had to be overcome. It was felt that if this could be done in such manner that the readings could be distributed in pre-determined proportions over the three scales, the use of straight line tuning potentiometers would become fully justified.

Crowding was least noticeable on the *A* scale, but crowding was found on the *C* scale. Therefore, it appeared that it should be possible to increase the scale ratio of the *A* scale and decrease it

most for the *C* scale, with the *B* scale representing a medium between these two; e.g., scale ratios of 3 : 1, 2 : 1 and 1½ : 1 for the *A*, *B*, and *C* scales, respectively. This was found to yield scale readings of 10 to 30, 30 to 60 and 60 to 100; Figure 3a.

In the previous analysis, it was pointed out that the *C* scale was directly affected by the *A* scale, as being timed

from the same potentiometer terminals *m*. If this procedure were to be retained and the paralleling process were to be applied without correction, the *C* scale, reading four times higher in values than the *A* scale, would read from 40 to 120. Since the corresponding maximum and minimum tuning resistances for the *A* and *C* scales with R_p ,

(Continued on page 30)

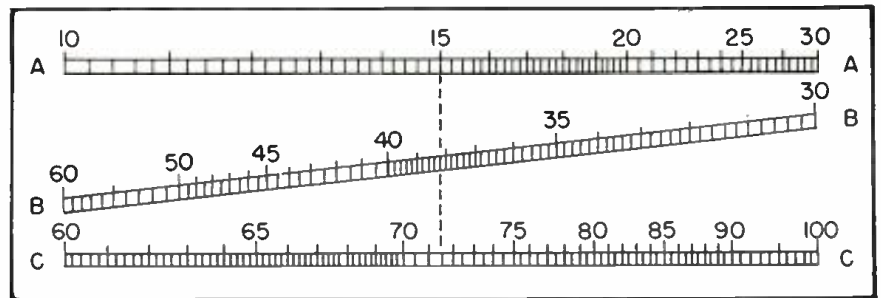
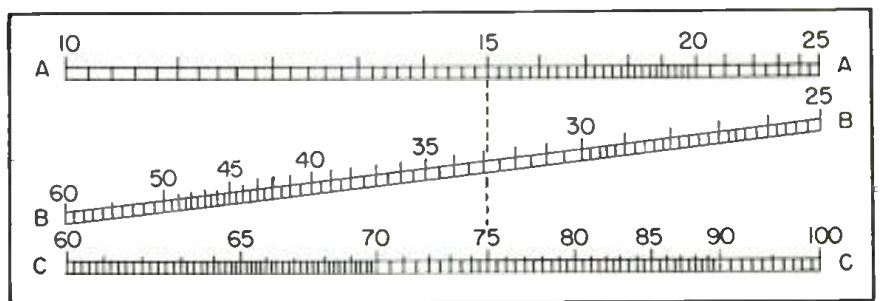
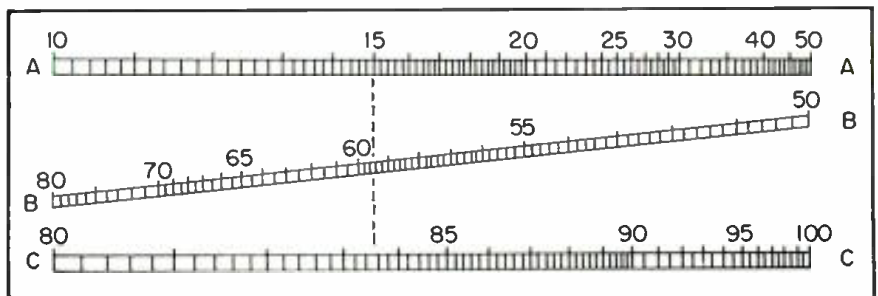

Figure 3a
Scale for completely equalized bandspreading.



Figures 3b and c (Above and below)
Additional scale layouts for completely equalized bandspreading





GUARDIAN CENTERING MAGNETS

The Guardian Centering Magnet compensates magnetically for any misalignment of the electronic beam of the focus coil assembly. Eliminates manual adjustment of the raster.



GUARDIAN FOCUS COILS

Over a million Focus Coils have rolled off Guardian's production lines into TV sets of leading manufacturers. With more than 75 types established as *Guardian standard*, speedy delivery to meet today's replacement needs is a matter of routine. Write.



GUARDIAN G ELECTRIC
1615J W. WALNUT STREET CHICAGO 12, ILLINOIS
A COMPLETE LINE OF RELAYS SERVING AMERICAN INDUSTRY

WHEN YOU CHANGE YOUR ADDRESS

Be sure to notify the
Subscription Department of



52 Vanderbilt Avenue
New York 17, N. Y.

The Post Office Department does not forward magazines unless you pay additional postage, and we cannot duplicate copies mailed to the old address. We ask your cooperation.

Bandspreading

(Continued from page 29)

equals 18,000 ohms and since S_a equals 3, in the 1a and 2a equation we find that:

For the A scale... $R_{maxa} = 54,000$ ohms

$R_{mina} = 18,000$ ohms

For the C scale... $R_{maxc} = 13,500$ ohms

$R_{minc} = 4,500$ ohms

Considering that the high-frequency end of the C scale must read 100, against the low-frequency end of the A scale 10, and the corresponding resistance for this reading on the A scale has been found to be 54,000 ohms, the 100 reading on the A scale must be obtained from a tuning resistance of $54,000/10$ or 5,400 ohms. The resistance of 5,400 ohms obtained from direct paralleling of the A scale for the highest reading on the C scale therefore must be increased.

Figure 4
Equivalent circuit for completely equalized tuning circuit for the C scale.

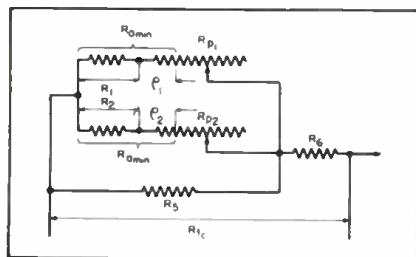

Similarly, the low-frequency end of the C scale must be $1\frac{2}{3}$ times 5,400 ohms or 9,000 ohms. This is less than the 13,500 ohms obtainable from straight paralleling and therefore, this resistance must be decreased.

From these considerations it was possible to arrive at an equivalent circuit for the C scale: Figure 4. The minimum resistance in this circuit is increased by the permanently present series resistor, R_0 , whereas the parallel combination of the two A-scale tuning circuits is lowered by the parallel resistor, R_0 . The resulting tuning resistance R_{t1} appears between the end terminals of this combination as shown.

The resistors, R_0 and R_{t1} , were calculated from the equations:

$$R_0 = \frac{R_p}{2(S_a - 1)} \times f \left\{ \frac{S_a + 1}{2(S_a - f - 1)} + \sqrt{\frac{S_a}{(S_a - f - 1)f} + \frac{S_a + 2}{2(S_a - f - 1)}} \right\} (1c)$$

in which

$$f = 4 \times \frac{1 - 1/S_c}{S_b}$$

$$R_{t1} = \frac{R_p}{2(S_a - 1)} \left\{ \frac{4}{S_b S_c} \frac{R_0}{R_0 + \frac{R_p}{2(S_a - 1)}} \right\} (2c)$$

The tuning resistance was plotted from the equation

$$R_{t1} = \frac{R_0}{1 + \frac{2R_0}{R_p \left(\sigma + \frac{1}{S_a - 1} \right)}} + R_0 (3c)$$

[To Be Concluded Next Month]

Color Tests

(Continued from page 22)

a contributing factor to this result. It has been found that the eye is much more sensitive to the brightness change which ordinarily accompanies a change in color than it is to the hue and saturation changes. A color system which responds with only hue and saturation changes to interfering signals in the vicinity of the color sampling frequency, such as oscillator radiation, is therefore visually more nearly immune to such interferences.²

The improved sampling arrangement has also been found to eliminate the tendency of the dot-sequential color signal to interfere with itself in the receiver, a characteristic particularly noticeable on fine patterns.

²One of the classic measuring instruments for comparing light intensities, the flicker photometer, makes use of this characteristic of the eye.

TV Antenna Tests

(Continued from page 11)

or supports when subjected to prolonged testing.

The vibration fatigue testing equipment in our lab consists of a power supply (1/2 hp motor), an eccentric to cause deflection of the test-mounting point, a variable speed control, and a frequency indicator. The variable-speed control is so designed as to provide an automatic change of vibration rate from 600 to 3,300 vibrations per minute, or the vibration rate may be manually set for any frequency desired, within this range and left there for prolonged test.

Wind Vibration Data

The effects of wind vibration on TV antennas, observed during actual installations over a period of ten to twelve years, have been found very helpful in planning our accelerated test schedules. For instance, it has been found possible to observe the development of distorting stresses and fatigue leading to breakage of antenna elements in about 8 to 10 minutes. However, after a study of failures and the redesigning of mechanical details, many antennas have been run for several hours. The test time set up by the armed forces is five minutes at each resonant frequency.

The antennas are tested in various positions with relation to the excursion of the test table. In this manner all conditions of wind vibrations are introduced to the antenna under test. At all resonant frequencies the amount of travel in the element is observed and measured. While the element is held at maximum resonance, any change in the point of stability or in the amount of flexing is indicative of mechanical failure at some point in the element.

Any mechanical change in the design of an antenna is subjected to the fatigue test. Tool changes are checked by the same means. Thus, a small amount of stoning in order to change the radius of a stamped part often means the difference of years in an actual installation.

Test Records

Records, kept on various tests, have been organized to disclose the natural period of vibration; time run at the resonant frequency; displacement of table travel; measurements of element



The **Q-METER**
TYPE 160-A

ACCURATE • DEPENDABLE • VERSATILE

For the measurement of Q, inductance, and capacitance, the 160-A Q-Meter is the universal choice of radio and electronics engineers. Its wide frequency coverage from 50 kc. to 75 mc. is an outstanding feature which makes possible the accurate and rapid evaluation of components and insulating materials at the actual operating frequency.

SPECIFICATIONS

OSCILLATOR FREQUENCY RANGE:
50 kc. to 75 mc. 8 self contained ranges.

OSCILLATOR FREQUENCY ACCURACY:
 $\pm 1\%$, 50 kc.-50 mc. $\pm 3\%$, 50 mc.-75 mc.

Q-MEASUREMENT RANGE: Directly calibrated in Q, 20-250. "Multiply-Q-By" Meter also at x2.5, extending Q-range to 625.

Q-MEASUREMENT ACCURACY: Approx-

mately 5% for direct reading measurement, for frequencies up to 30 mc. Accuracy less at higher frequencies.

CAPACITANCE CALIBRATION RANGE:
Main capacitor section 30-450 mmf, accuracy 1% or 1 mmf, whichever is greater. Vernier capacitor section ± 3 mmf., zero, -3 mmf. calibrated in 0.1 mmf. steps. Accuracy ± 0.1 mmf.

Write for literature containing further details

BOONTON RADIO

BOONTON • N.J. • U.S.A.

Corporation



flexing; design changes recommended for dampening of vibrations; and the failures, if any.

In view of the trend towards less expensive antennas, testing by this vibration fatigue method becomes extremely significant. At present there are three types of antenna elements used, namely, seamless aluminum tubing, split tubing, and solid rod. In these categories there are various weights, diameters and wall thicknesses used. Differences in characteristics of these various types are again multiplied by the mounting style at the cross-arm, and by the vibration snubbers usually consisting of wood dowels or aluminum pins inserted in the terminal end of the antenna element.

Of course, the mechanical modifications deemed necessary must be made without altering the essential electrical characteristics of the antenna. Antennas are designed primarily for certain electrical characteristics, and then the mechanical aspects are worked out. The latter consideration is highly important to the TV Service Man, since the initial cost of the antenna is normally not the greatest economic factor. Any antenna that requires call-backs, due to mechanical failure, is too expensive at any price. The cheapest antenna is one properly engineered to withstand the ravages of time and weather.

Streamlined Chassis

(Continued from page 13)

insulation were not provided between windings, the high voltage present might cause a breakdown with consequent damage to the receiver. The power transformers were also made to conform to another special spec, the capacity of the filament winding for the damper tube. Since the capacity in these windings is across the tuned circuit of the horizontal output circuit, it must be accurate. It is this tuned circuit which makes possible horizontal retrace. If a transformer with a different value of capacitance is used, the effect may be a decrease in picture width, with a decrease in brightness, and possibly fold-over.

In the primary of the power transformer, an interlock was provided. This interlock differs from that used in some previous models, in that it is a true interlock. That is, when the back of the cabinet is removed, no voltage is present at the chassis. In some previous models, although the back cover was removed, voltage was still present in the receiver, including the high voltage. This provision was found to be an additional safety feature.

BIRTCHEr
STAINLESS STEEL - LOCKING TYPE
TUBE CLAMPS

Stainless Steel Corrosion Proof



83 VARIATIONS

Where vibration is a problem, Birtcher locking TUBE CLAMPS offer a foolproof, practical solution. Recommended for all types of tubes and similar plug-in components.

More than three million of these clamps in use.

FREE CATALOG

Send for samples of Birtcher stainless steel tube clamps and our standard catalog listing tube base types, recommended clamp designs, and price list.

THE BIRTCHEr CORPORATION
5087 HUNTINGTON DR. LOS ANGELES 32

FOR ACCURATE TESTING OF COMMUNICATION AND TELEVISION COMPONENTS UNDER LOAD CONDITIONS



FREED NO. 1110 INCREMENTAL INDUCTANCE BRIDGE

Designed for measuring the inductance of Iron Core components for frequencies up to 10000 cycles. Inductors can be measured with super-imposed direct current. Ideal instrument for manufacturers and users of iron core components for communications and television.

Accuracy 1%
Inductance Range 1 millihenry to 10,000 Hy.
Maximum current 1 Amp DC

Recommended Accessories:
AC Supply \approx 1180 DC Supply \approx 1170
Null Detector \approx 1140 or Vacuum Tube Voltmeter and Null Detector \approx 1210

SEND FOR THE NEW FREED CATALOG

FREED TRANSFORMER CO., INC.
1718 WEIRFIELD STREET
BROOKLYN (Ridgewood) 27, NEW YORK

Briefly Speaking . . .

NEW APPLICATIONS OF TV have become quite an activity on the video line. Recently the flying-spot scanner has been probed by Philco for use on railroads as a reservation and record identification system. . . . TV set production continues to soar. During the first half of '50, the output was equal to the entire year's production of '49. Specifically, RTMA member-companies reported the manufacture of nearly two-and-a-half million TV chassis in the first half of '50 as against around 900,000 during the corresponding period of 1949. . . . A new course in *Vacuum Tube Circuits* has been instituted by the Graduate Division of the N.Y.U. College of Engineering. The course, under the supervision of Assistant Professor James H. Mulligan, will cover comprehensive studies of the analysis and design of vacuum-tube circuits in communication engineering. . . . Five cameras, one of which is equipped with a Zoomar lens, are now being used by WPIX to telecast the home games of the N. Y. Giants at the Polo Grounds in New York City. . . . A resistance-capacitance oscillator, which covers in five steps a range from 20 cps to 2 mc. has been developed by Peter G. Sulzer at the National Bureau of Standards. The oscillator circuit has two feedback paths: a regenerative cathode-to-cathode loop, and a degenerative cathode-to-grid-loop which includes a bridged-T network. . . . James D. Secrett has become the secretary and general manager of RTMA, succeeding Bond Geddes, who will continue to serve the association as a consultant. . . . Ralph Batcher is the new chief engineer of the RTMA Engineering Department, succeeding L. C. F. Horle, who has retired after 15 years of association service. . . . James M. Blackledge, chairman of the Association of Electronic Parts and Equipment Manufacturers has organized an electronics-industry mobilization committee to plan, coordinate and advise government agencies in defense conversion and production. James P. Quam has been named chairman of the committee which includes William J. Halligan (Hallcrafters); Jerome J. Kahn (Standard Transformer); John H. Cashman (Radio Craftsmen); S. N. Shure (Shure Bros.); Herbert C. Clough (Belden); and H. E. Kunz (Sangamo Electric). . . . The sixth annual Pacific Electronic Exhibit, to be held in the Municipal Auditorium, Long Beach, Calif., September 13, 14 and 15, will be host to nearly 60 exhibitors in the electronic and allied fields. The annual West Coast Convention of the IRE will be held simultaneously with the exhibit. . . . An electronic core division for iron powder electronic-core manufacturers has been announced by the Metal Powder Association, 120 Lexington Ave., New York 17, N. Y. Membership in the new division includes Magnetic Core Corp., Ossining, N. Y.; National Moldite Co., Hillside, N. J.; Powdered Metal Products Corp. of America, Franklin Park, Ill.; Pyroferrie Co., New York, N. Y.; Radio Cores, Inc., Oaklawn, Ill.; The Speer Resistor Co., and Stackpole Carbon Co., St. Marys, Pa. . . . Rectangular picture tubes are now being produced by Reeves Soundcraft Corp., at their Springdale, Conn., plant. Production details are available from the Colorcraft Tube Division of Reeves at 35-51 36th St., Long Island City 6, N. Y.



HOTEL STRAND

ATLANTIC CITY'S IDEAL CONVENTION HOTEL

Exceptional Convention Facilities adaptable to small, medium or large groups. Ample Meeting, Banquet and Exhibition Rooms. Wonderful location on Boardwalk opposite Steel Pier, the center of Atlantic City. Write Convention Manager TODAY.

The Strand features Spacious Colorful Lounges—Open and Inclosed Solaria—Salt Water Baths in Rooms—Garage on premises. Courteous Personnel.

When in Atlantic City visit FAMOUS FIESTA LOUNGE "Food for Epicures"

Exclusive Penna. Avenue and Boardwalk

ADVERTISERS IN THIS ISSUE

TELEVISION ENGINEERING

AUGUST, 1950

AUDIT BUREAU OF CIRCULATIONS.....	23
BIRTCHEr CORPORATION	32
Agency: Crossley & Jeffries, Inc.	
BOONTON RADIO CORP.	31
Agency: Frederick Smith	
CLAROSTAT MFG. CO., INC. Inside Front Cover	
Agency: Austin C. Lescaillon & Staff	
FREED TRANSFORMER CO.	32
Agency: Franklin Mfg. Service	
GENERAL RADIO CO. Back Cover	
Agency: The Banta Press	
GUARDIAN ELECTRIC CO.	30
Agency: Kennedy & Co.	
MEASUREMENTS CORPORATION	1
Agency: Frederick Smith	
RADIO CORPORATION OF AMERICA	
Agency: J. Walter Thompson Co. Inside Back Cover	
HOTEL STRAND	32
SYLVANIA ELECTRIC PRODUCTS CO., INC.	3
Agency: Cecil & Presbury, Inc.	
U. S. TREASURY DEPT.	26

**Video
Monoscope
Camera
TK-1A**

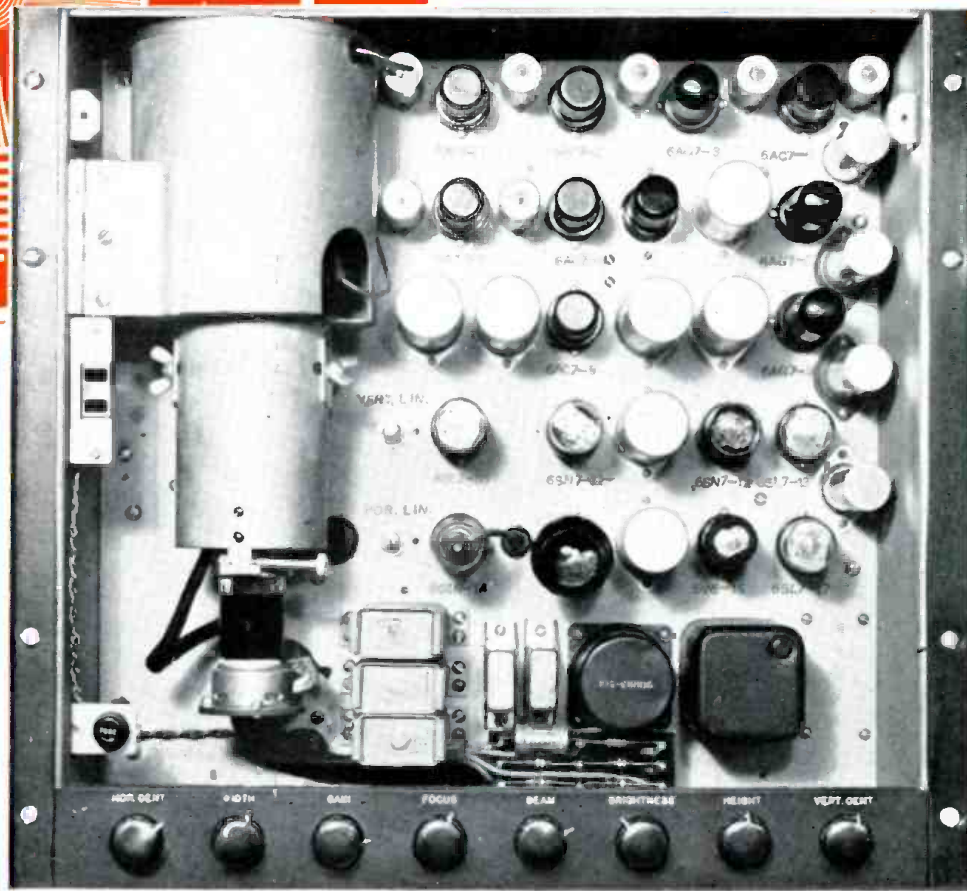

... "patternmaker" for the industry

The test pattern produced by RCA Monoscope Cameras is the standard by which picture quality has been judged since the beginning of electronic television . . . in TV stations . . . in laboratories . . . in TV receiver production.

These are the standard test-pattern cameras used by many TV receiver manufacturers. These are the standard "picture micrometers" used by TV stations to make precision measurements of video transmissions.

Deliberately designed to excel in all things, RCA Monoscope Cameras have earned the extraordinary re-

spect of television men. Evenly lighted patterns as steady as Gibraltar. Resolution as fixed as the cut of a diamond. Operation as reliable as a ship's chronometer.

Type TK-1A pictured here is RCA's newest Monoscope Camera—built to the highest standards known. It can be delivered to you with the familiar monoscope pattern (shown above)—or with a pattern of your own choice.

Ask your RCA Television Equipment Sales Engineer for prices. Mail the coupon for data.



TELEVISION BROADCAST EQUIPMENT
RADIO CORPORATION of AMERICA
ENGINEERING PRODUCTS DEPARTMENT, CAMDEN, N. J.

In Canada: RCA VICTOR Company Limited, Montreal

Radio Corporation of America
Television Broadcast Equipment Section
Dept. 23H, Camden, N. J.

Send me your technical bulletin on the RCA Type TK-1A Monoscope Camera.

Name _____
Company or station _____
Address _____
City _____ State _____

For Impedance Measurements Between 70 and 1,000 Mc

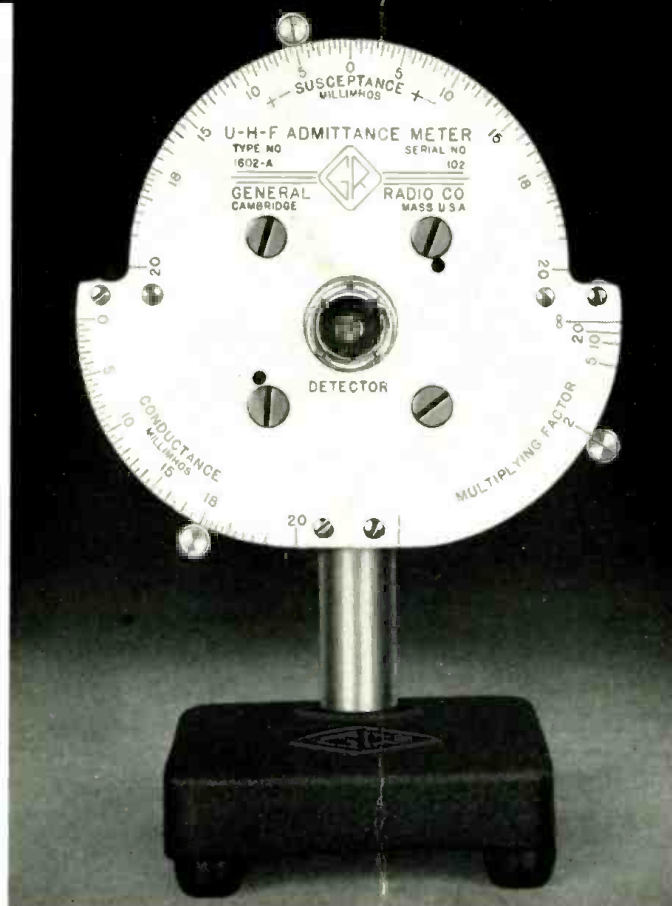

A NEW G-R Null-Type ADMITTANCE METER

AS A NULL INSTRUMENT MEASURES Conductances and Susceptances, of either sign, from 1 millimho to 400 millimhos (1,000 ohms to 2.5 ohms).

AS A DIRECT-READING DEVICE DETERMINES Magnitude of Reflection Coefficient of coaxial systems and Magnitude of unknown Impedance and Admittance.

AS A COMPARATOR INDICATES Equality of one Admittance to another and the degree of departure of one from the other.

REPRESENTING an entirely new and unique technique in instrumentation, the new G-R Type 1602-A U-H-F Admittance Meter makes possible rapid, simple and accurate measurements of impedance in the range between the upper limit of conventional bridge circuits and the lower limit of practical slotted lines—70 to 1,000 Mc. (With an accessory Type 874-L30 Air Line, range can be extended to 50 Mc.)

Operating and design features include:

- PRACTICAL OPERATING RANGE of 200 micromhos to 1,000 millimhos
- DIALS CALIBRATED in Conductive and Susceptive components of the unknown Admittance
- DIALS DIRECT-READING at the operating frequency when the stub (supplied with the instrument) is set to that frequency
- CALIBRATION independent of frequency
- BUILT-IN ACCURACY independent of the calibration of an external detector or generator
- VERY SIMPLE TO MATCH the unknown to 50 ohms
- METER INDICATION shows approach toward matching
- HIGH ACCURACY for both Conductance and Susceptance: from 0 to 20 millimhos $\pm (5\% + 0.2 \text{ millimho})$; 20 to ∞ millimhos $\pm 5 \sqrt{\text{SCALE MULTIPLYING FACTOR}}\%$; an unknown can be compared to an arbitrary standard with still higher accuracy
- A SMALL, LIGHTWEIGHT, PORTABLE and COMPACT UNIT, ideal for field use
- ACCESSORIES SUPPLIED: Type 874-WM 50-ohm Termination for use as Conductance standard; one Type 1602-P2 Adjustable Stub (70 to 500 Mc) and one Type 1602-P1 Adjustable Stub (150 to 1,000 Mc) for Susceptance standards; two Type 874-R20 Patch Cords for connections to generator and detector.

TYPE 1602-A U-H-F ADMITTANCE METER . . . \$295.00



GENERAL RADIO COMPANY

Cambridge 39,
Massachusetts

90 West St., New York 6 920 S. Michigan Ave., Chicago 5 1000 N. Seward St., Los Angeles 38